



Daikin Inverter Wall Mounted Split Type

大金變頻掛牆分體機

Operation and Installation Manual 使用安裝說明書

25/35型

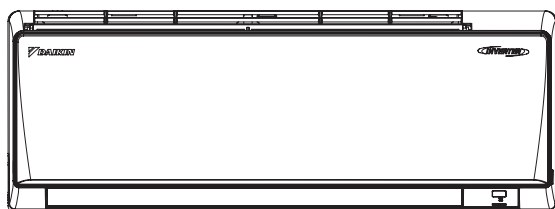

50/60/71型

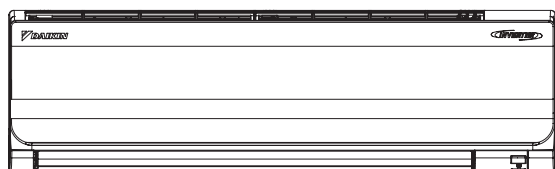

Please read this manual carefully before use and keep it properly for future reference.

使用前請仔細閱讀本說明書，並保留此說明書以備日後參考。

Models

型號

FTKP25MV1H
<RKP25MV1H>
FTKP35MV1H
<RKP35MV1H>
FTKP50MV1H
<RKP50MV1H>
FTKP60MV1H
<RKP60MV1H>
FTKP71MV1H
<RKP71MV1H>

SSID lable



R32 is classified as mildly flammable refrigerant. Consumers shall consult supplier, agents or his authorized technicians for installation, inspection and maintenance for this type of product. Consumers shall pay attention to installation height and minimum floor area for such product's indoor unit installation.

R32屬於輕度易燃製冷劑。消費者如購買該類產品，請留意及確認室內機安裝高度及室內空間最少建築面積，應向供應商、代理商或具有處理相關雪種經驗的技術人員聯絡，安排進行安裝、檢查或維修。

For a Better Experience

Clean air filters regularly

- Clogged air filters will affect the cooling performance.

▶ P.29

Keep the space around the air conditioner clear

- It may affect the performance or lead to machine failure.

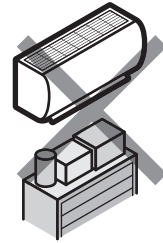

Set a moderate temperature range

- Keep the temperature setting at a moderate level helps save energy.

<Set a moderate temperature range>
Cooling...26°C~28°C

Disconnect the power supply when not in use for an extended period

- The air conditioner still consumes 2.0W of power even when it is not in use. Please switch off the power when the unit is left idle for an extended period of time, e.g., in spring or autumn.

TIMER Operation

- Activate TIMER operation to switch the air conditioner on or off at night or in the morning; the ON/OFF TIMER can be used together.

▶ P.26

Do not block the air inlet and outlet

- It may affect the performance or lead to machine failure.



Cover windows with a blind or a curtain

- Block the sunlight and airflow to enhance the cooling performance.

Table of Contents (Operation)



Safety Precautions 4
Names and Functions of Parts 7
Preparation Before Operation 11

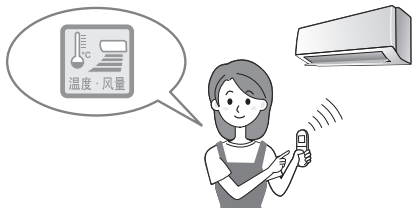

Smart Control 13
Wireless Connection Setting 14
DRY/COOL/FAN ONLY Operation 15
Adjusting the Airflow Direction 17



COMFORT AIRFLOW Operation 19
CLEAN Operation 20
COMFORT SLEEP Operation 21
POWERFUL Operation 22
ECONO Operation 23
OUTDOOR UNIT QUIET Operation 24
MOULD PROOF Operation 25
TIMER Operation 26



Care and Cleaning 28



FAQs 31
Troubleshooting 33

Table of Contents (Installation)





Safety Precautions for Installation 35
Accessories 36







Installation Sites 36
Precautions for Installation 39
Installation of Refrigerant Pipe 40
Installation of Indoor Unit 42
Installation of Outdoor Unit 47
Test and Commissioning 51
Repair and Maintenance 52

Safety Precautions



- Keep this manual where the user can easily find it.
- Read this manual carefully before installing, using or repairing the air conditioner.
- For safety reasons, please observe the following precautions.
- The precautions described herein are classified as WARNING and CAUTION. They both contain important information regarding safety. Please observe all precautions strictly.

 WARNING Failure to strictly observe these instructions may result in serious damage to the air conditioner and pose a risk of injury or fatality to individuals.	 CAUTION Improper operation may result in personal injury, equipment damage, or severe consequences.
---	--

 Never attempt.	 Follow strictly.
 Earthing required.	 Never wet the air conditioner or the remote controller.
 Never touch the air conditioner or the remote controller with wet hands.	



WARNING

- | | |
|--|---|
| 
Never attempt | <ul style="list-style-type: none"> • To avoid fire, explosion, or injury, do not use the unit when flammable or corrosive gases are detected near it. • Prolonged exposure to the airflow from the unit may undermine your health. • Do not place objects, including rods or fingers, in the air inlet or outlet. • Do not attempt to repair, relocate, modify, or reinstall the unit as improper handling may result in electric shock or fire. Please contact Daikin sales engineers to repair or reinstall the unit or replace damaged cables. |
| 
Follow strictly | <ul style="list-style-type: none"> • If the unit is not cooling properly, there may be a refrigerant leak. Please contact sales engineers for assistance. Please consult the technician for details after the unit is repaired or the refrigerant is refilled. • To avoid electric shock, fire, or injury, stop using the unit immediately and turn off the power if an abnormality (e.g., a burning smell) is detected. Please contact sales engineers for assistance. • Install a residual current device (compatible with high harmonic models) depending on the actual environment to avoid electric shock or fire. • The unit is filled with colourless and odourless mildly flammable Grade A2L refrigerant R32. • Do not keep the unit in a place with a constant heat source, e.g., open flame, gas burner, gas heater, gas stove, or operating electric heater. • Do not pierce or burn the unit. • Do not use any means to accelerate the defrosting process or to clean the frozen parts, other than those recommended by the manufacturer. • The unit should be placed properly to avoid machinery damages caused by accidents. • Install the indoor unit at least 1.8m above the ground. Systems with total refrigerant charge lower than 1.84kg are not subjected to any room area requirements. |

- Laws and regulations on gases should be observed.
- The unit should be kept in a well-ventilated room meeting the size requirement stated in this document.
- Do not attempt to install the unit. Improper installation may result in water leak, electric shock, or fire. Please contact sales engineers to install, relocate or repair the unit. Unauthorised personnel are not allowed to do so.
- Please contact sales engineers for repair and maintenance. The task must be performed in strict compliance with the operation manual provided by the manufacturer. The unit shall not be repaired by any non-professional personnel.
- The unit must be installed, relocated, and repaired by professionals in accordance with the regulations and this manual.



Please read the operation manual carefully.



Please read the installation manual carefully.



Please read the service manual carefully.



WARNING: mildly flammable



Earthing required

- The unit must be earthed. Improper earthing may result in electric shock. Do not connect the earthing wire to a gas pipe, water pipe, lightning rod, or a telephone earthing line.

Electrical work

- A separate power circuit dedicated to the air conditioner must be used.

System relocation

- Specialised knowledge and skills are required when relocating the unit due to addition, renovation, or relocation. Please contact sales engineers for assistance.

Qualification requirements for technicians

- All technicians should obtain valid certificates issued by industry-recognised accreditation organisations to ensure that they are qualified to handle the refrigerant safely according to the recognised industry standards.
- Equipment should be installed, maintained and repaired according to the methods recommended by the manufacturer. If assistance from other professionals is required for installation, maintenance and repair works, it should be conducted under the supervision of qualified individuals with R32 refrigerant handling qualification.

CAUTION



Never attempt

- Do not use the air conditioner for preserving precision instruments, food, plants, animals, or works of art to avoid affecting the quality of the object concerned adversely.
- Do not expose young children, plants, or animals directly to the cool airflow from the unit.
- Do not block the air discharge and suction to avoid poor performance or machine failure.
- Do not stand or sit on the outdoor unit, put anything on top of the air conditioner, or remove the discharge air grille to avoid injury or accident.
- Do not place any objects that are easily damaged by moisture directly beneath the indoor or outdoor units, as condensation may occur.
- Check the unit stand and mounts for any sign of damage after prolonged use.
- To avoid injury, do not touch the aluminium fins of the air suction of the outdoor unit.
- Only connect the air conditioner to a dedicated power circuit to avoid machine failure or fire.
- The unit is not intended for use by unattended young children or mentally incapacitated people.
- Children should be supervised to ensure that they do not play with the unit.
- To avoid injury or accident, do not open the front panel when the unit is operating.

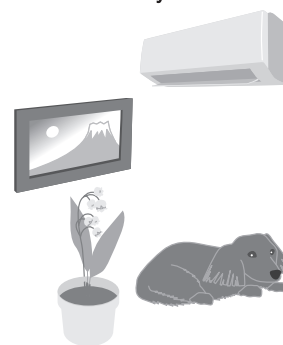

Follow strictly

- Before cleaning, make sure to switch off the unit and the power.
- The drain hose should be arranged to ensure smooth drainage as improper drainage may cause leakage and property damage.
- Keep the outdoor unit free of any obstacles or leaves. Any leaves or small animals entering the unit and coming into contact with the electrical parts may cause machine failure, smoke, or fire.
- To protect the environment and safeguard the health and safety of human and animals, do not discharge the refrigerant into the atmosphere. The refrigerant must be recovered using specialised equipment.



No wet hands

- Do not operate with wet hands.



Keep dry

- Do not wash the indoor unit with excessive water. Just wipe it using a lightly damp cloth.
- Do not place water containers or vessels on the unit as the moisture may weaken the electrical insulation and result in electric shock.

Installation Sites

- Consult sales engineers when the unit will be installed in the following environments.
 - Oily, steamy, or smoking places.
 - Places where the air has a high salt content, such as coastal areas.
 - Places with a high level of sulfide gas, such as hot springs.
 - Places where the outdoor unit may be covered in snow.
- The drain-water hole of the outdoor unit must be installed at a place with good drainage.

Consider potential noise nuisance to neighbours

- Please choose an installation site that meets the following requirements.
 - A steady place that can support the weight of the unit without amplifying the operation noise or vibration.
 - A place where the air discharged from the outdoor unit or the operation noise will not disturb your neighbours.

Names and Functions of Parts

Indoor unit Model 25/35

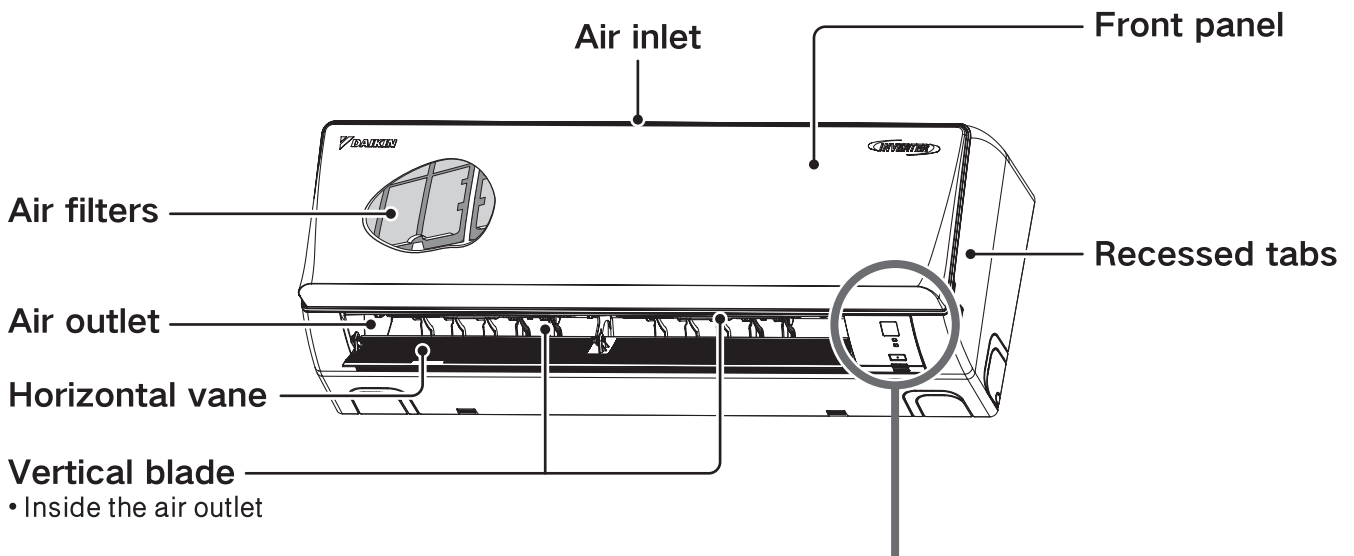

Display

Signal receiver

- It receives signals from the remote controller.
- When the unit receives a signal, you will hear a beep sound.
- Operation starts: beep-beep
- Setting changed: beep
- Operation stops: long beep

Room temperature sensor

- Detect the room temperature

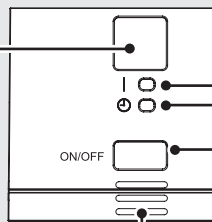

OPERATION lamp (green)
CLEAN operation

TIMER lamp (yellow)

ON/OFF switch

- Press the switch once to turn on the unit and press again to stop it.
- This switch is handy when the remote controller is missing.

Outdoor unit Model 25/35

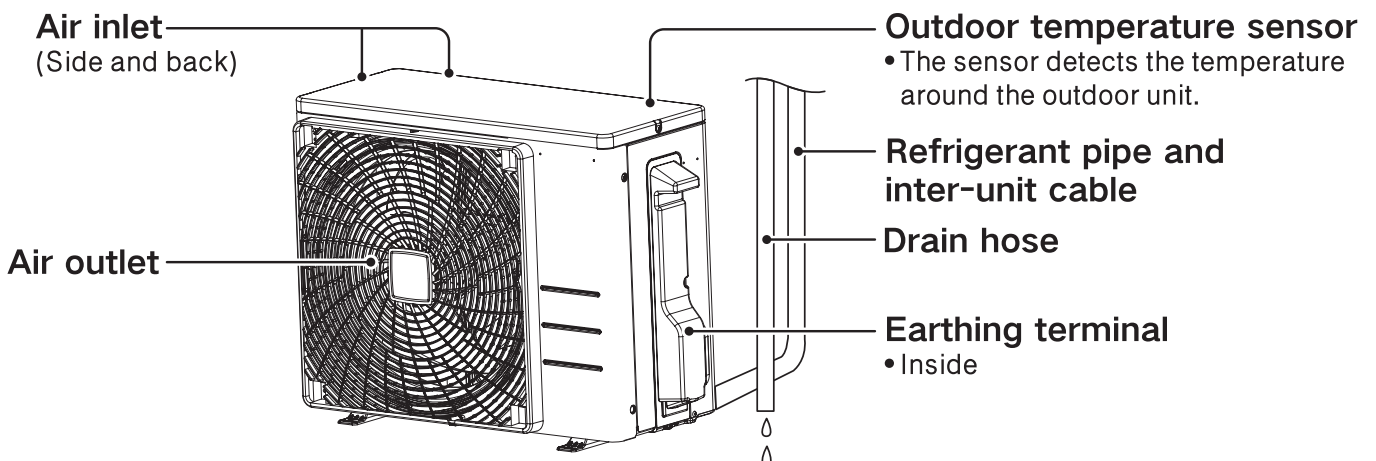

The appearance of the outdoor unit may be different from the image shown.

Indoor unit Model 50/60/71

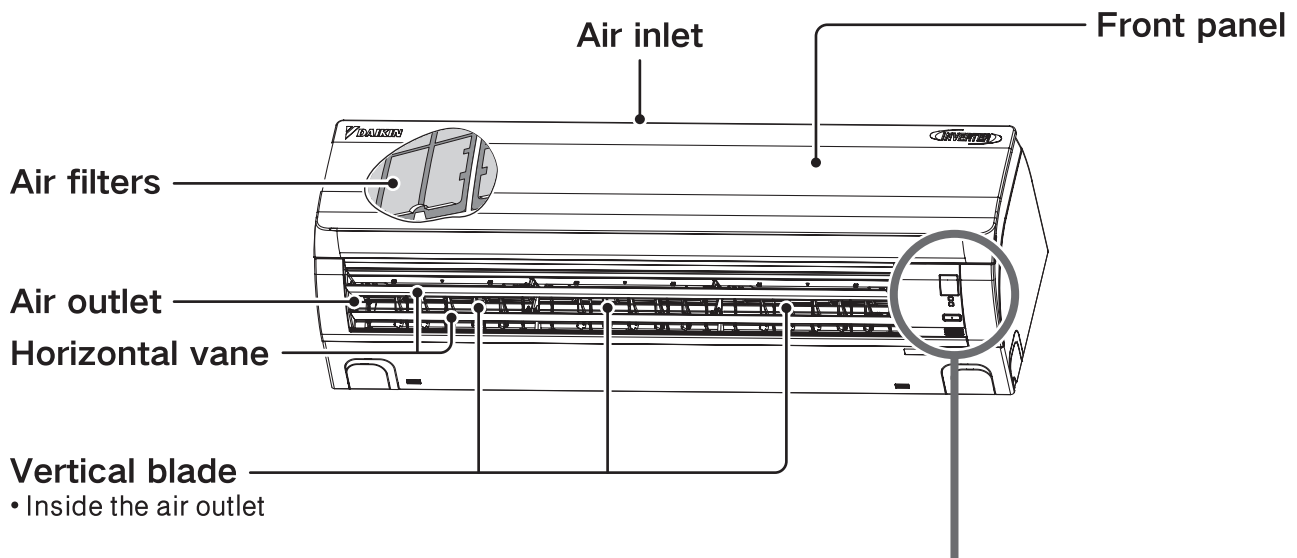

Display

Signal receiver

- It receives signals from the remote controller.
- When the unit receives a signal, you will hear a beep sound.
- Operation starts: beep-beep
- Setting changed: beep
- Operation stops: long beep

Room temperature sensor

- Detect the room temperature

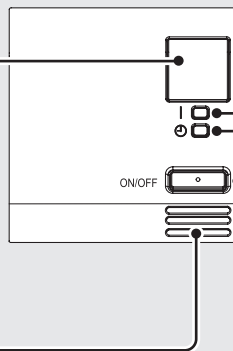

OPERATION lamp (green) CLEAN operation

TIMER lamp (yellow)

ON/OFF switch

- Press the switch once to turn on the unit and press again to stop it.
- This switch is handy when the remote controller is missing.

Outdoor unit Model 50/60/71

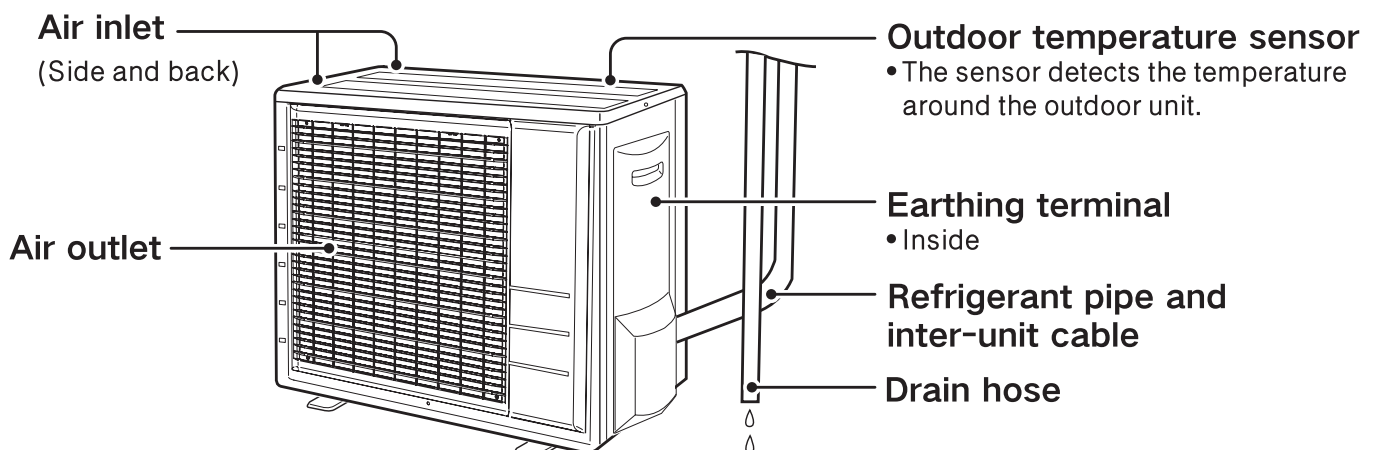

The appearance of the outdoor unit may be different from the image shown.

Remote Controller

Operation

COOL

COOL button.

- Lower the room temperature.

FAN ONLY

FAN ONLY button.

- Improve the ventilation.

DRY

DRY button.

- Lower the indoor humidity.

OFF: **OFF** button

The display of the remote controller will be turned off.

Operation display

The current setting is shown here (all operation modes are shown in the image for illustration purpose. The actual display may be different, subject to the model).

Signal transmitter

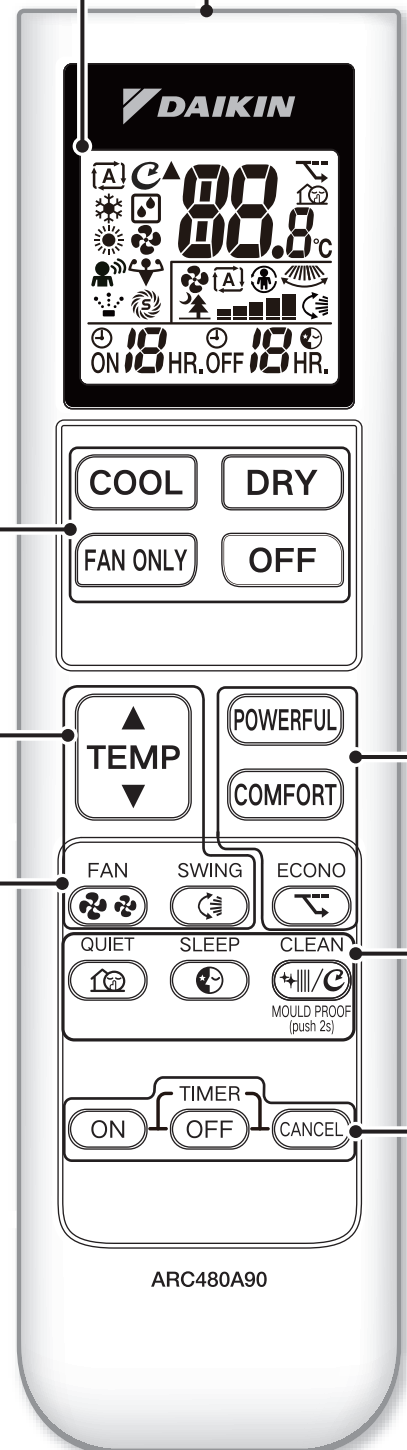

Temperature, airflow, and airflow direction adjustment

Temperature



- Adjust the temperature setting under COOL mode.
- Adjust the level of DRY mode.

Airflow



- Adjust the airflow under COOL and FAN ONLY modes.

Vertical Auto-Swing (up and down)



- Adjust the airflow direction vertically.

Easy Setup

POWERFUL Operation



- Maximise the performance of the air conditioner in current mode.
- This function can enhance the performance of the unit during operation.

COMFORT AIRFLOW Operation



- This function controls the airflow of the cool air to deliver a more comfortable experience.

ECONO Operation



- Limit the maximum power consumption.
- Minimise the power consumption of the air conditioner when there is too much electrical load.

OUTDOOR UNIT QUIET Operation



- Lower the operation sound of the outdoor unit to create a quiet environment.
- This function helps you to sleep comfortably at night and minimise the impact on neighbours.

COMFORT SLEEP Operation



- Set your sleep time for better sleep.

CLEAN/MOULD PROOF Operation



- CLEAN operation (press): Remove the dust and dirt on the heat exchanger (see P.20 for details).
- MOULD PROOF operation (press and hold for 2 seconds): Lower the humidity inside the unit to inhibit the spread of mould and odour.

Easy Setup

ON TIMER Operation



- Set the timer to switch the air conditioner on at a specified time.

OFF TIMER Operation



- Set the timer to switch the air conditioner off at a specified time.

Cancel



- Cancel the ON or OFF TIMER.
- Cancel the COMFORT SLEEP operation.

Preparation Before Operation

Remote Controller

Insert the batteries

1 Slide the battery lid to the direction marked by  to open.

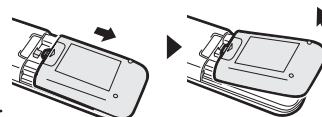

2 Insert two pieces of AAA dry-cell batteries.

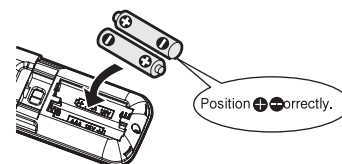

3 Put the battery lid back.

Operate the remote controller

- To use the remote controller, aim the signal transmitter at the signal receiver of the indoor unit. If there is anything blocking the signals between the unit and the remote controller, such as a curtain, the unit may not respond.
- Do not drop the remote controller or get it wet.
- The maximum distance for signal transmission is 7m.

Model 25/35

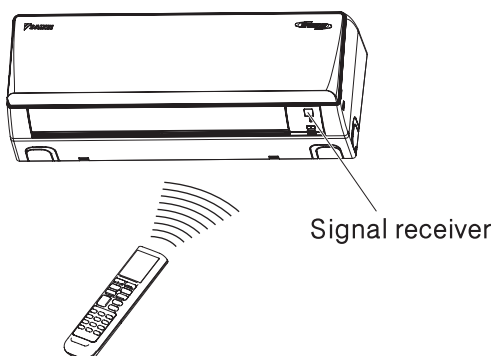

Model 50/60/71

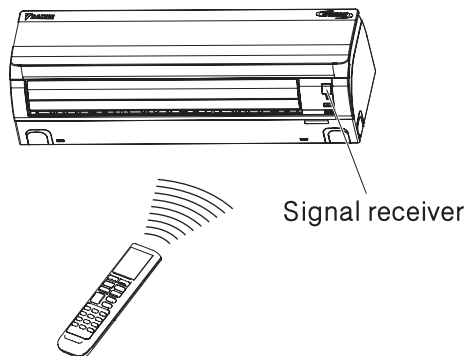

Notes on batteries

- When replacing the batteries, use batteries of the same type and replace the two old batteries together.
- Take out the batteries when the unit is not in use for extended period.
- We recommend replacing the batteries once a year. However, if the display goes dim or the reception becomes weak, replace the old batteries with two new AAA batteries immediately.
- The batteries provided are for initial operation. The life of the batteries varies, depending on the manufacture date of the air conditioner.
- The batteries must be replaced and disposed safely before they corrode.

Notes on the remote controller

- Dust on the signal transmitter or receiver will reduce the sensitivity. Wipe off the dust with a soft cloth.
- Signal transmission may be affected if there is a fluorescent lamp with electronic ignitor (such as fluorescent lamp with rectifier) in the same room. In this case, please consult sales engineers.
- If any appliances respond to the signal of the remote controller, move those appliances to somewhere else or consult sales engineers.
- If there is anything between the unit's signal receiver and the signal transmitter of the remote controller, signal reception may be affected, and the air conditioner may not respond.

Turn on the power

- Once the power is turned on, the flaps will open and close in order (this is not a malfunction).

Proper use of the unit

- Do not set the room temperature too low/too high. Set the temperature within a moderate range.
- Cover windows with a blind or a curtain. Block the sunlight and airflow can enhance the cooling performance.
- Clogged air filters will affect the cooling performance and increase power consumption. We recommend cleaning the filters every two weeks.

Set a moderate temperature range

Cooling · · · · · 26°C ~ 28°C

Please bear in mind

- The air conditioner still consumes 2.0W of power even when it is not in use.
- Please switch off the power when the unit is left idle for an extended period of time.
- Please use the air conditioner in the following environment.

Operation modes	Operating conditions	Consequences if the unit does not operate under such conditions
COOL	Outdoor temperature: 10 ~ 46°C Indoor temperature: 18 ~ 32°C Indoor humidity: below 80%	<ul style="list-style-type: none"> • The safety device will be activated, and the unit may stop running. • Dew may form on the indoor unit and water dripping may occur
DRY	Outdoor temperature: 10 ~ 46°C Indoor temperature: 18 ~ 32°C Indoor humidity: below 80%	<ul style="list-style-type: none"> • The safety device will be activated, and the unit may stop running. • Dew may form on the indoor unit and water dripping may occur.
CLEAN	Outdoor temperature: above 3°C	<ul style="list-style-type: none"> • There is a buzzing sound, but the CLEAN operation does not start.

- In addition to not meeting the above operating conditions, the safety device may also be activated due to other reasons, and the unit may stop running.
- When the outdoor temperature falls below -15°C, the air conditioner will stop running.

Smart Control

■ How to download Daikin Advance?

- Search “Daikin Advance” on Google Play for Android devices.
Search “Daikin Advance” on App Store for iOS devices.

Notes:

- Please check the device operating system version. This application supports Android 6.0 and iOS 12.0 or later versions (the requirements on the operating system may change with the upgrades of the application. Please refer to the requirements when you download the application).
- The user interface of the application may be different, subject to the version or operating system. Please refer to the application for actual user interface.
- Since the settings controlled through the application will not be displayed on the wireless remote controller, the content shown on the remote controller may differ.
- Make sure that your device and air conditioners are connected to the network.
- Do not use this air conditioner near microwave ovens or any other devices with a radio frequency of 2.4GHz as the transmission of the wireless signal may be affected.

Wireless Connection Setting

■ Preparation before setting



- The router must be connected to the internet. Make sure that the power is on to ensure proper operation.

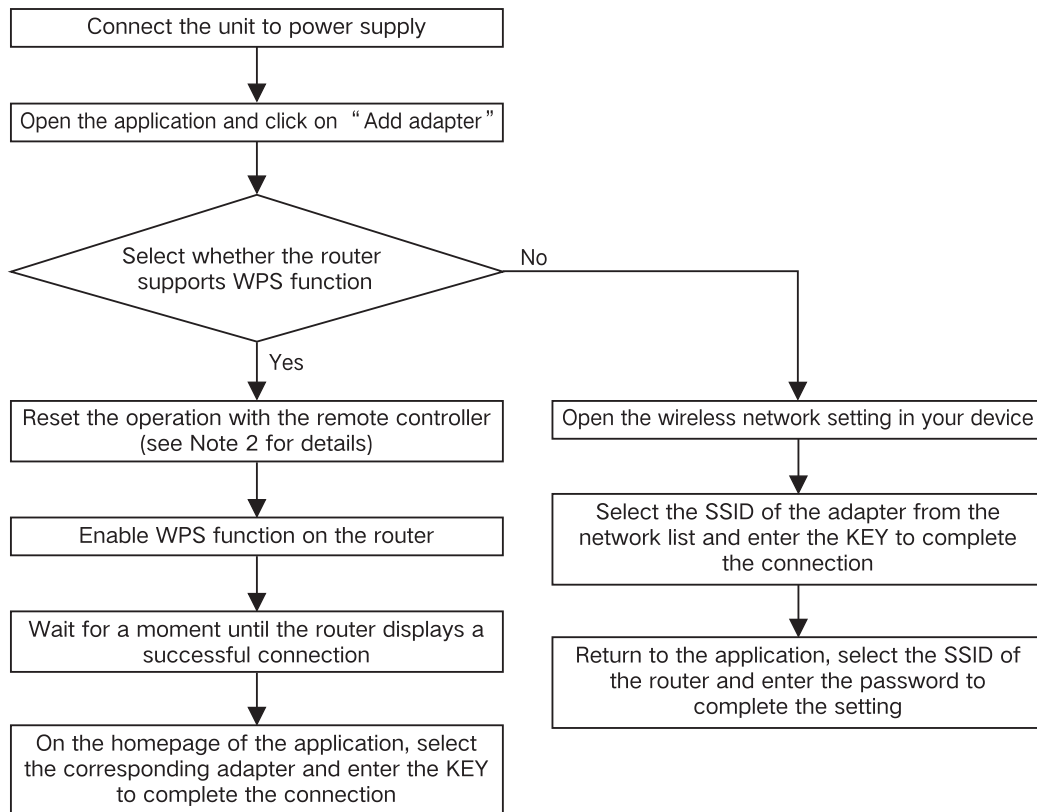

■ Configuration



Note 1: For detailed configuration instructions, please refer to the guidelines in the application and proceed step by step accordingly.

Note 2: Ensure that the unit is not in operation when resetting the Wi-Fi (switching the unit off does not mean that the operation stops as the unit may continue to run some modes even after it is switched off. Please wait patiently until the unit shuts down completely).

To reset the Wi-Fi with the remote controller, press and hold “” for 5 seconds when the remote controller is off. Wait until “” appears on the display (as shown on the right).

Press “” to until “” is shown on the display (as shown on the right). Press “” to confirm.

Note 3: If network abnormality occurs during the configuration process, please check if the router network is functioning properly.

If yes, turn off and turn on the power supply again to restart device, or reset the Wi-Fi to restore the network.

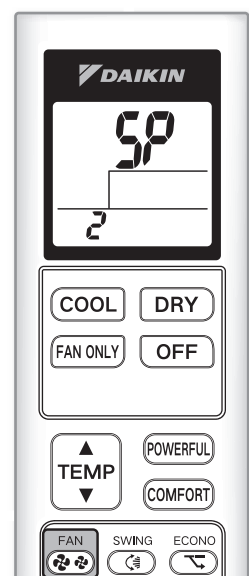

DRY/COOL/FAN ONLY Operation

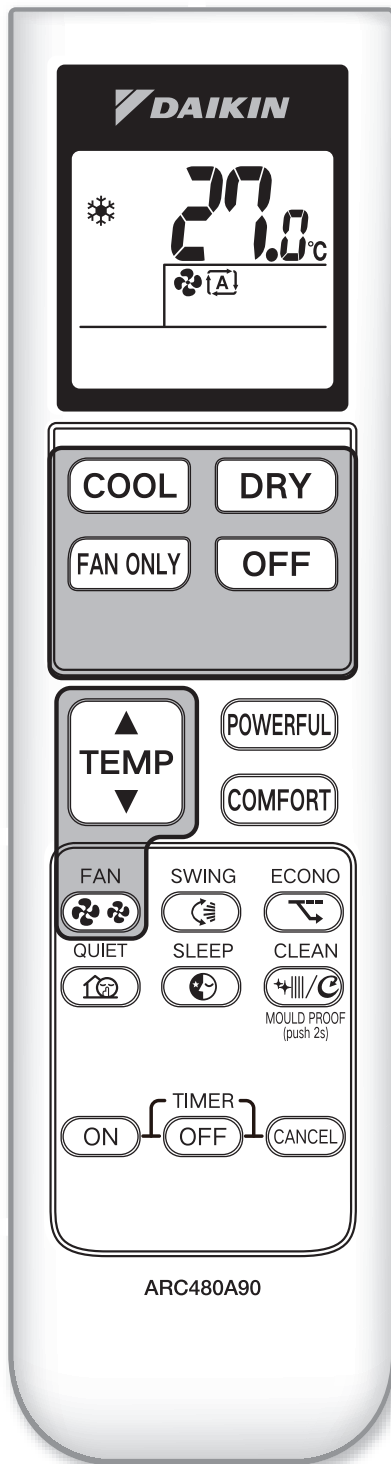

The air conditioner comes with three operating modes, including COOL, DRY, and FAN ONLY, to meet your needs.

To start operation

Press “ **COOL** ”, “ **DRY** ” or “ **FAN ONLY** ” to start an operation mode.

※ Image illustrated with model 25/35.

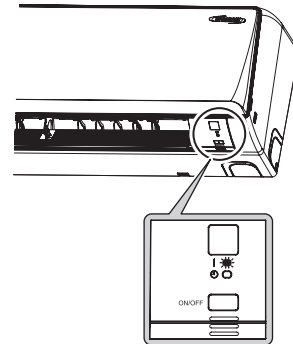

- The operation lamp lights (green).

To stop operation

Press “ **OFF** ”.

Adjust the temperature

Press “ **TEMP** ”.

FAN ONLY operation	The temperature cannot be changed.
COOL operation	Press “ ▲ ” to raise the temperature and press “ ▼ ” to lower the temperature.
	Set your preferred temperature. 27.5°C 
DRY operation	Press “ ▲ ” to raise the temperature and press “ ▼ ” to lower the temperature and control the dehumidification capacity (adjustment range: ± 2°C).

Adjust the airflow

Press “  ”.

DRY operation	The airflow cannot be changed.
COOL, FAN ONLY operation	 The unit supports five levels of airflow, from “lowest” to “highest”, complemented with AUTO and QUIET modes.

- **INDOOR UNIT QUIET operation**

When the airflow is set to “”, the indoor unit will minimise the operation sound.

The performance of the unit will be affected if the airflow is set to “low”.

Notes on COOL operation

- Since this air conditioner cools the room by releasing the heat in the room outside, the cooling performance may be degraded if the outdoor temperature is too high.
- Once the desired temperature is reached, the temperature and humidity will remain at a comfortable level.

Notes on DRY operation

- The computer chip works to lower the room humidity while maintaining the room temperature.
- The cold air mixes with the air in the room after dehumidification to adjust the temperature and lower the room humidity.
- The air conditioner automatically controls the temperature and airflow. The setpoint temperature cannot be adjusted manually.
- When the outdoor temperature is lower than the indoor temperature, the dehumidification performance will be affected.

Notes on airflow setting

- The cooling capacity will be smaller when the airflow is lower.

Adjusting the Airflow Direction

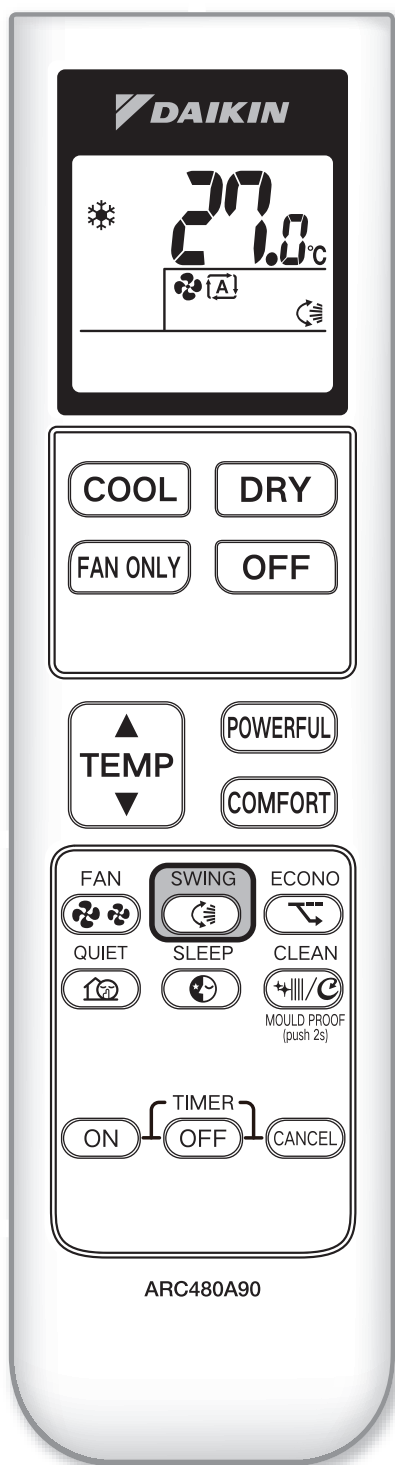

You can adjust the airflow direction for optimal comfort.

Adjust the horizontal vane

Press “”.

- “” appears on the display. The horizontal vane begins to swing vertically.

Press “” again when the horizontal vane reaches the desired position.

- The display disappears.
- The horizontal vane stops moving.

Adjust the vertical blade

- Hold the tabs and move them left and right (there is a tab on each side of the vane).
- To adjust the airflow direction, the remote controller should be used to adjust the horizontal vane. The vertical blade should be adjusted when the unit is not in operation.

Notes on adjusting the airflow direction

- If the unit is installed in the corner, the vertical blade should not face the wall as it may block the airflow from the unit, affecting the cooling performance as a result.

Notes on the angle of the horizontal vane

- After pressing “”, the swing angle of the horizontal vane will depend on the operation mode (see the image below).

Model 25/35

DRY or COOL operation

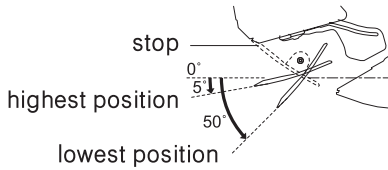

FAN ONLY operation

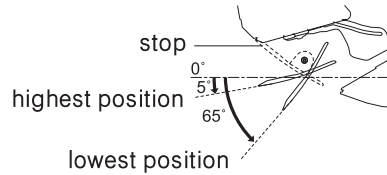

Model 50/60/71

DRY or COOL operation

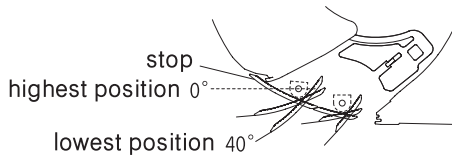

FAN ONLY operation

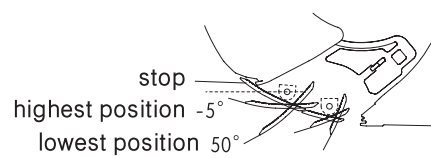

CAUTION

- If you adjust the horizontal vane by hand forcibly during operation, it may damage the unit. Since the fan inside the air outlet is running at high speed, adjusting the vertical blade manually during operation may cause injury.

COMFORT AIRFLOW Operation

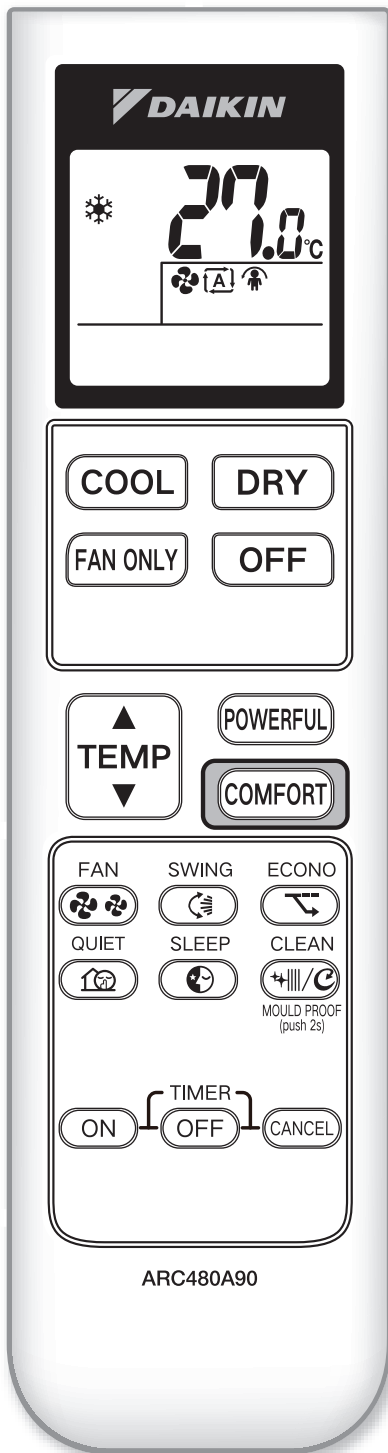

The unit adjusts the airflow direction automatically to distribute the air evenly throughout the room, preventing the cool air from blowing directly onto the people in the room.

To start COMFORT AIRFLOW operation

Press “**COMFORT**”.

- “” appears on the display in COOL, DRY, FAN ONLY operation.

To cancel COMFORT AIRFLOW operation

Press “**COMFORT**” again.

- “” disappears from the display.
- The horizontal vane will return to the original position before the COMFORT AIRFLOW operation starts running.

Notes on COMFORT AIRFLOW operation

- <In the COOL, DRY and FAN ONLY operation> The vane swings up and stops.

The vane swings up:

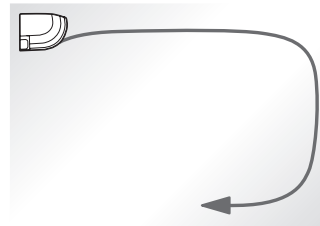



Swing angle of the horizontal vane:

Model 25/35

Model 50/60/71



With a special design, the horizontal vane swings up to prevent the cool air from blowing directly onto the people in the room.

- The Coanda airflow refers to the airflow generated by Coanda effect.
- You can adjust the airflow in the COMFORT AIRFLOW operation. Automatic airflow is recommended.
- The performance will be affected if the airflow is set to “low”.
- If the airflow along the ceiling is blocked, the effect of COMFORT AIRFLOW operation will be affected.
- In COMFORT AIRFLOW operation, the horizontal vane is controlled automatically by the computer chip, which is normal.
- When pressing “**POWERFUL**”, “”, the COMFORT AIRFLOW operation will be cancelled and “” will disappear from the display.

CLEAN operation

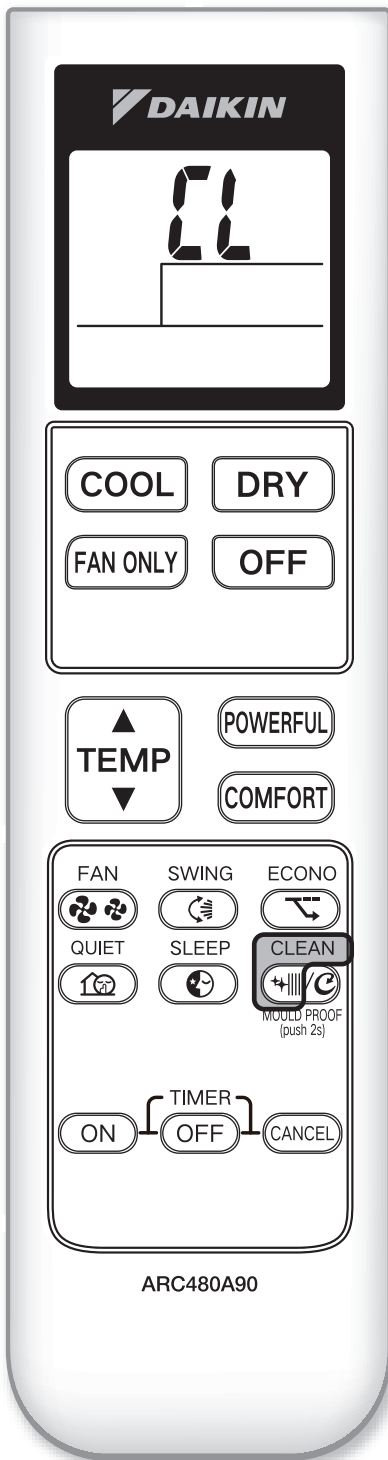

The unit effectively removes the dirt on and unpleasant odour from the heat exchanger by cleaning it with condensed water before drying.

Start CLEAN operation

Press “” when the unit is not in operation.

- “” flashes twice on the display.
- The CLEAN operation starts.
- The CLEAN lamp lights.

Stop CLEAN operation

Press “” again.

- “” flashes twice on the display.
- The CLEAN operation stops.
- The CLEAN lamp goes off.

Notes on CLEAN operation

- To protect the unit, the CLEAN operation cannot be activated when the outdoor temperature falls below 3°C, which is not a malfunction.
- In the CLEAN operation, the process of cleaning with condensed water and drying lasts about 2 hours.
- The unit may generate a low operation sound and cool air in the CLEAN operation, which is not a malfunction. This function is recommended to be used when no one is in the room.
- The ideal temperature and humidity range for cleaning the unit using condensed water: room temperature: 15° C - 27° C; indoor humidity: 30% - 60%. The cleaning performance may be affected in environments beyond this range. Please clean the unit in environments that fall within this range.
- In the CLEAN operation, press “**COOL**”, “**DRY**”, “**FAN ONLY**” to stop the CLEAN operation. After that, the air conditioner will operate according to the remote controller setting. The “**OFF**” function is disabled in the CLEAN operation. The unit with Wi-Fi connection cannot be controlled via the application in the CLEAN operation.
- In the CLEAN operation, pressing “” (MOULD PROOF operation) will stop the CLEAN operation but the MOULD PROOF operation will not be activated at this point.
- In the CLEAN operation, the position of the horizontal vane is fixed and cannot be adjusted with the remote controller.

※ Image illustrated with model 25/35.

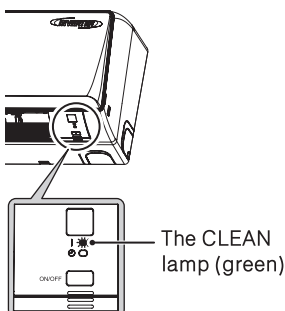



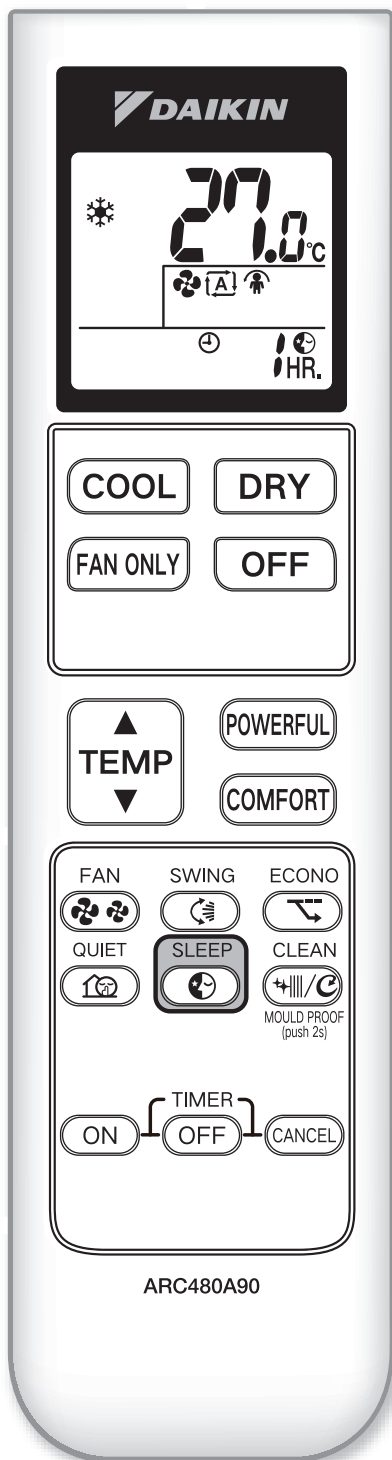

COMFORT SLEEP Operation





As our body temperature decreases during sleep, this function gradually lowers the temperature at night and raises the temperature in the morning (V-shaped temperature control) to ensure a good night's sleep.

Set the COMFORT SLEEP operation

- Press “” in the COOL mode.
- “  HR.” appears on the display.
- Press “” to set the wake-up time (1-12 hours). Each press extends the time by 1 hour.



Cancel COMFORT SLEEP operation

- Press “”.
- “  HR.” disappears from the display.

Notes on COMFORT SLEEP operation

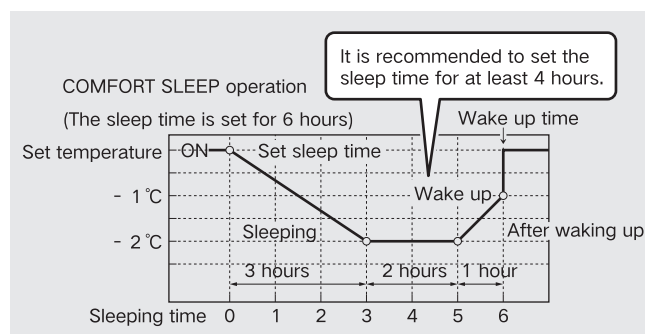
- The setting will be stored once the operation is set (the operation has to be reset after the batteries are replaced).
- Once the COMFORT SLEEP operation is set, the temperature will decrease by 2°C in the first 3 hours and increase by 1°C around 1 hour before the pre-set wake up time. The original temperature setting will be restored when the COMFORT SLEEP operation ends.



- This function can only be used in the COOL operation.
- This function cannot be used with the TIMER. The first function selected takes priority.
- In the COMFORT SLEEP operation, the vertical airflow is fixed. The airflow is set to AUTO.
- The OPERATION lamp of the indoor unit is off in the COMFORT SLEEP operation, which is not a malfunction.
- In the COMFORT SLEEP operation, “”, “”, “” cannot be used.

POWERFUL Operation

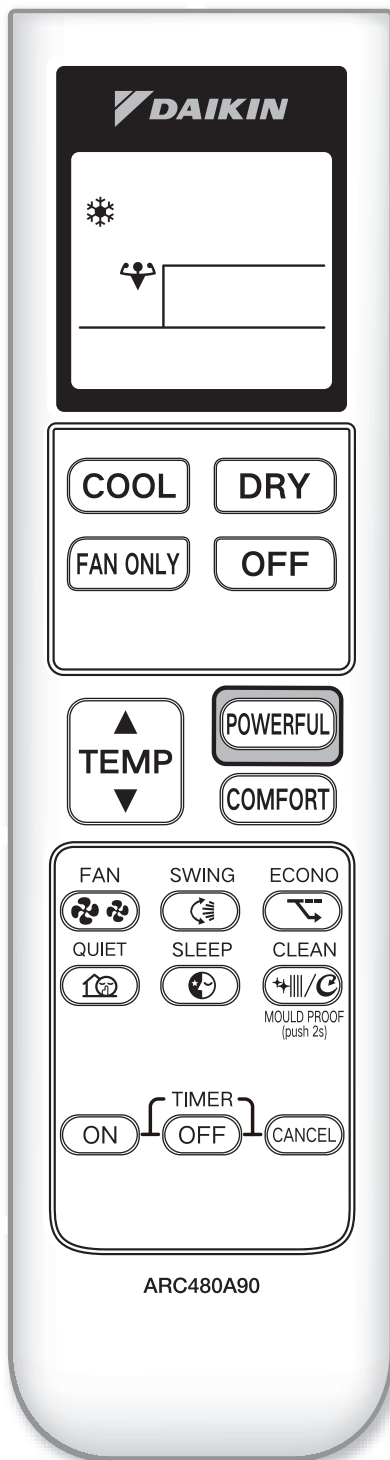

This function immediately maximises the capacity in COOL mode. This function cannot be used in DRY, FAN ONLY mode.

Start POWERFUL operation

Press “**POWERFUL**”.





- “” appears on the display.

Cancel POWERFUL operation

Press “**POWERFUL**” again.

- “” disappears from the display.

Notes on POWERFUL operation

- The unit will restore its last setting after the POWERFUL operation has been activated for 20 minutes.
“” will disappear from the display.
- In COOL operation:
Enhance the cooling performance in COOL operation.
The temperature and airflow setting cannot be changed.
- The POWERFUL operation can only be used when the unit is in operation.
- Press “**COMFORT**”, “”, “”, “” to cancel the POWERFUL operation. “” will disappear from the display.

ECONO Operation

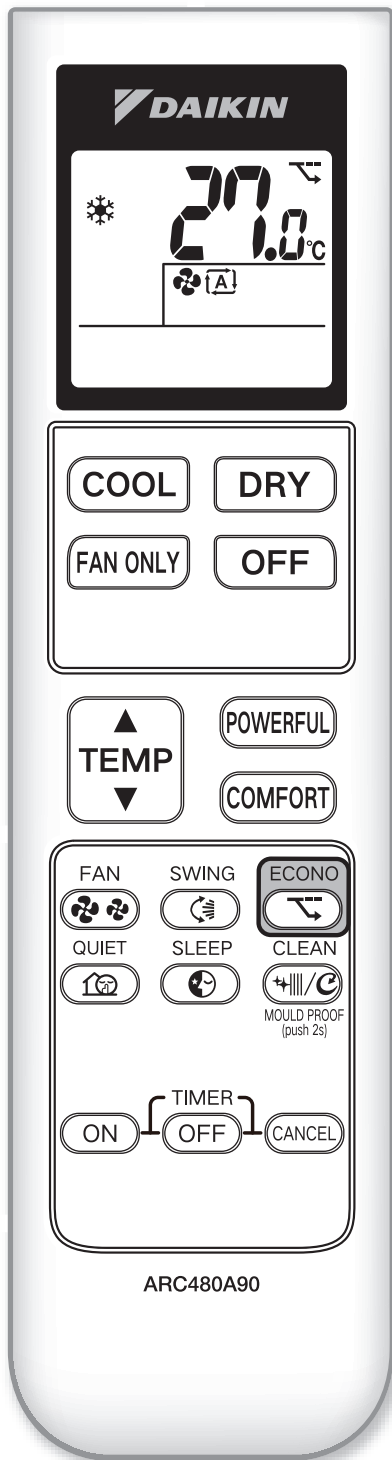

This function limits the maximum power consumption.

Start ECONO operation

Press “”.



- “” appears on the display.

Cancel ECONO operation

Press “” again.

- “” disappears from the display.

Notes on ECONO operation

- The ECONO operation can only be set and used in COOL, DRY operation. Once the operation stops, the setting will be cancelled, and “” will disappear from the display (this function cannot be used in FAN ONLY mode).
- Press “” to cancel the ECONO operation. “” will disappear from the display (except in DRY mode).
- The cooling, and dehumidification performance will be affected in this mode.
- When the power consumption is already low, the ECONO operation may not be able to save power.

OUTDOOR UNIT QUIET Operation

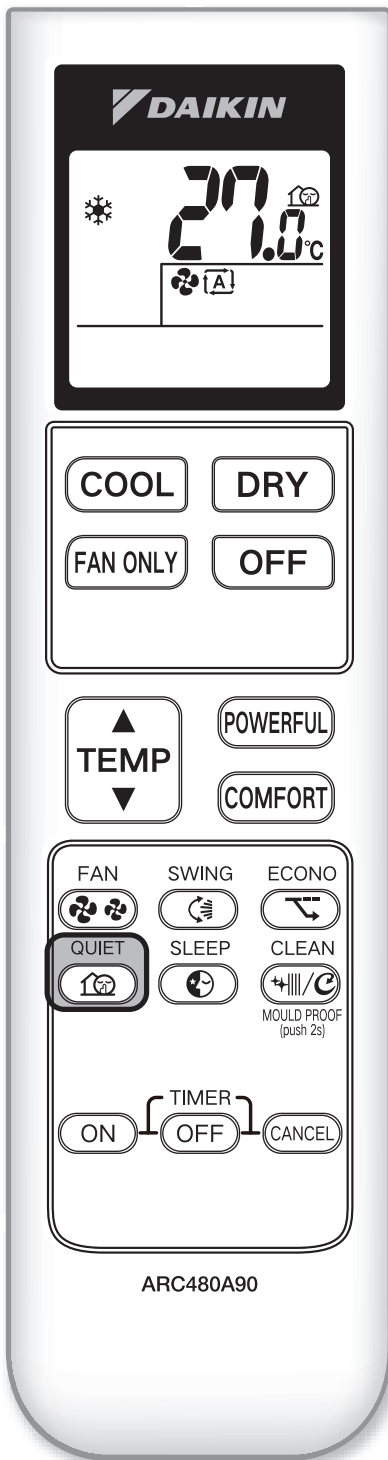

The OUTDOOR UNIT QUIET operation minimises the operation noise of the outdoor unit by changing the compressor frequency and fan speed of the outdoor unit. This function is useful to create a quite environment at night.

Start OUTDOOR UNIT QUIET operation

Press “”.



- “” appears on the display.

Cancel OUTDOOR UNIT QUIET operation

Press “” again.

- “” disappears from the display.

Notes on OUTDOOR UNIT QUIET operation

- This function can only be used in COOL operation (this function cannot be used in FAN ONLY and DRY operation).
- Press “” to cancel the OUTDOOR UNIT QUIET operation. “” will disappear from the display.
- The cooling performance will be affected in this mode.

MOULD PROOF Operation

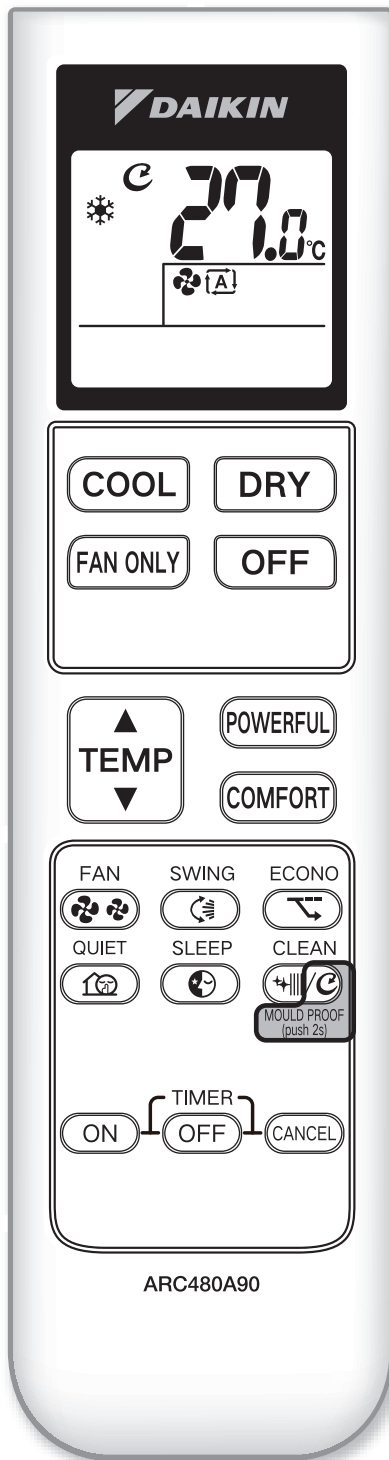

The MOULD PROOF operation inhibits the spread of mould and unpleasant odour by lowering the humidity inside the indoor unit in FAN ONLY mode. This operation can be set to run automatically or to be used whenever you need it.

Set the automatic MOULD PROOF operation

This function is set to "OFF" as default

- Press and hold "⏏/C" for 2 seconds when the unit is operating.
- "C" appears on the display.
- After running in COOL, DRY mode for a period of time and then turning off, the automatic MOULD PROOF operation will start automatically.

Cancel the automatic MOULD PROOF operation

- Press and hold "⏏/C" for 2 seconds.
- "C" disappears from the display.

Start the MOULD PROOF operation manually

- Press and hold "⏏/C" for 2 seconds when the unit is off.
- "C" flashes twice on the display.
- The MOULD PROOF operation starts.

Stop the MOULD PROOF operation manually

- Press and hold "⏏/C" for 2 seconds in the MOULD PROOF operation.
- "C" flashes twice on the display.
- The MOULD PROOF operation stops (the setting for automatic MOULD PROOF operation remains unchanged).

Notes on MOULD PROOF operation

- The automatic MOULD PROOF operation will run for 1.5 hours after the COOL, DRY operation turns off. The power consumption is about 0.014kWh.
- The fan will keep running, during the automatic MOULD PROOF operation, which is not a malfunction.
- The automatic MOULD PROOF operation is not designed to remove attached dust or mould.
- The automatic MOULD PROOF operation cannot be activated when the OFF TIMER is in operation.

TIMER Operation

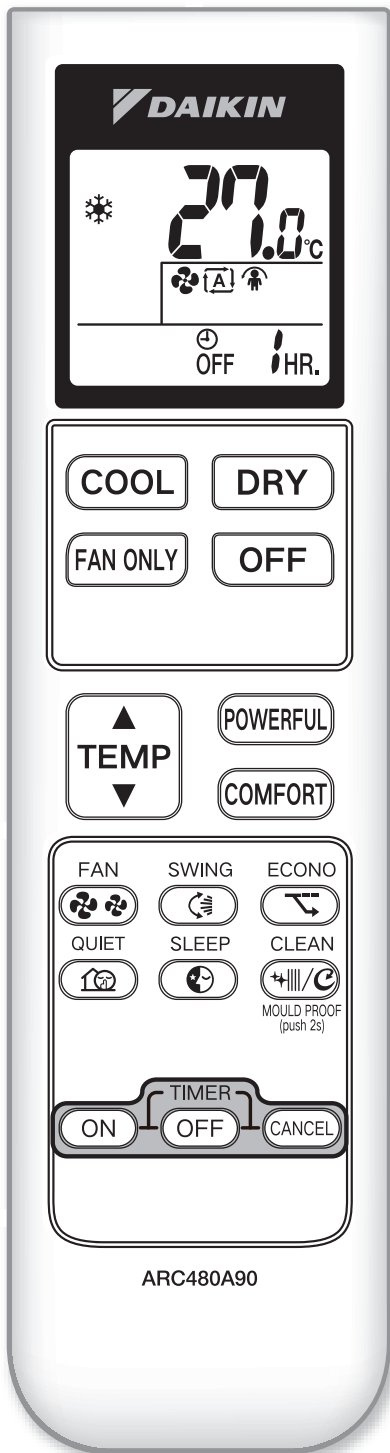

The ON TIMER and OFF TIMER automatically turn the unit on or off at set time.

Use automatic OFF TIMER

Press “OFF”.

“OFF 1 HR.” appears on the display.

The TIMER lamp lights.

- Press “OFF” until your preferred time appears on the display.
- The TIMER can be set between 1-12 hours. The time will extend by 1 hour with each press of “OFF”.

※Image illustrated with model 25/35.

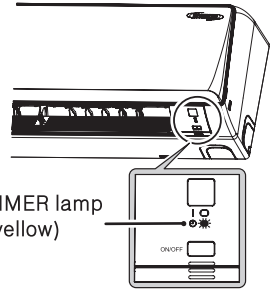

Cancel OFF TIMER operation

Press “CANCEL”.

- “OFF 1 HR.” disappears from the display.
- The TIMER lamp goes off.

TIMER Operation

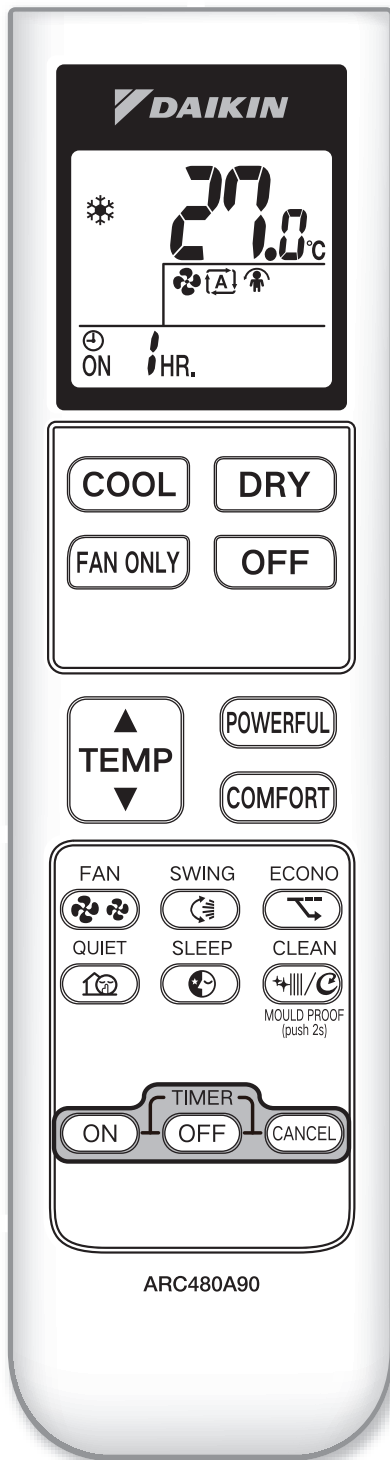

Use automatic ON TIMER

Press “**ON**”.

“**ON 1HR.**” appears on the display.

The TIMER lamp lights.

- Press “**ON**” until your preferred time appears on the display.
- The TIMER can be set between 1-12 hours. The time will extend by 1 hour with each press of “**ON**”.

※Image illustrated with model 25/35.

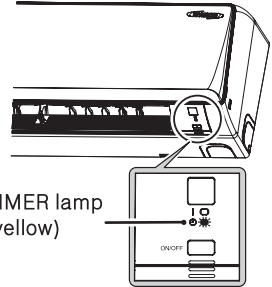

Cancel ON TIMER operation

Press “**CANCEL**”.

- “**ON 1HR.**” disappears from the display.
- The TIMER lamp goes off.

Use ON TIMER and OFF TIMER together

When using ON TIMER and OFF TIMER together, please refer to the following example.

Example

Turn off the unit after 3 hours;
Turn on the unit after 8 hours



ON 8HR. OFF 3HR.

⚠ CAUTION

■ In the following cases, please reset the timer.

- After the power is turned off.
- After a power failure.
- After replacing the batteries in the remote controller.
- The timer cannot be used with COMFORT SLEEP operation. The first function selected takes priority.
- The setting will be stored once the operation is set (the operation has to be reset after the batteries are replaced).

Care and Cleaning

⚠ CAUTION

- Before cleaning, please switch off the unit and turn off the power.

Air conditioning equipment

Indoor unit, outdoor unit, and remote controller

Wipe with a dry, soft cloth.

Front panel

※Image illustrated with model 25/35.

1 Open the front panel.

- Hold the recessed tabs on both sides of the indoor unit and open the front panel.

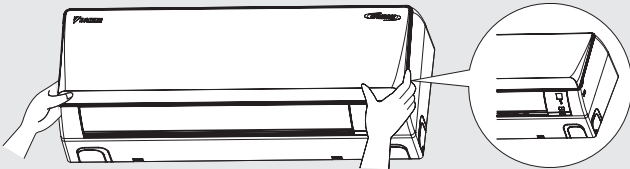

2 Remove the front panel.

- Slide the front panel slightly to the right and gently push it up. Pull out the front panel to disengage the rotating shaft on the bottom right side.

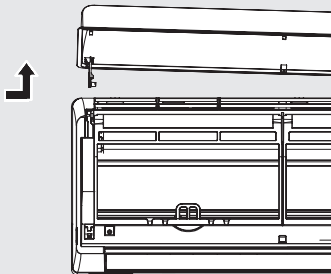

3 Clean the front panel.

- Wipe it with a soft damp cloth (only neutral detergent should be used).
- Wipe the cleaned front panel with a cloth. Dry it in the shade.

4 Install the front panel.

- Align the hooks of the front panel with the grooves and press them all the way in.
- Close the front panel gently and press the 3 marked spots (right, left and in the middle).

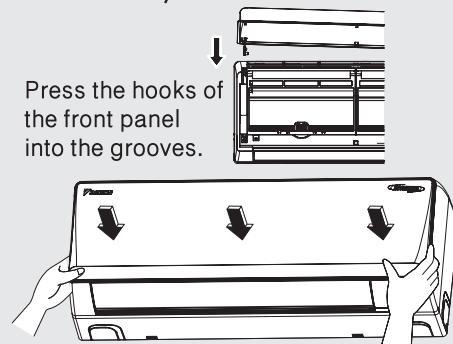

⚠ CAUTION

- Do not touch the metal parts of the indoor unit as this may cause injury.
- Do not use the following items that may deform or scratch the parts:
 - Hot water of 40° C or above;
 - Volatile substances such as volatile oil, petrol and thinner;
 - Polishing compounds;
 - Rough materials such as a brush.
- Please use a robust and stable ladder when cleaning the front panel. Watch your steps.
- Please contact sales engineers to replace the front panel if needed. Non-professional handling may cause damage to the panel or prevent it from functioning properly.

Care and Cleaning

If the air filters are dirty



CAUTION

- Please use a robust and stable ladder when opening or closing the front panel. Watch your steps.

Air filters

※Image illustrated with model 25/35.

1 Open the front panel.

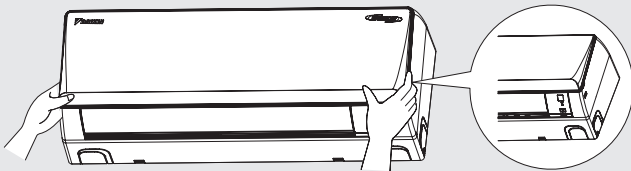

2 Pull out the air filters.

- Lift the rotating knobs on both sides then pull down the air filters.

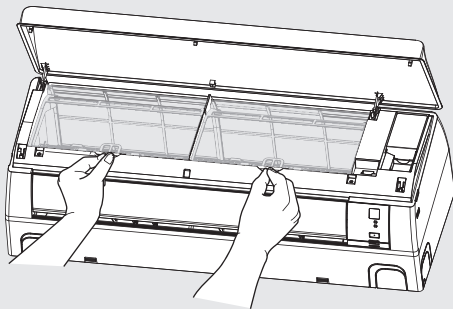

3 Clean or replace the air filters.

- See the instructions below.

4 Reinstall the air filters and close the front panel.

- Press the filter tabs into the grooves on the front grille.

Close the front panel gently and press the 3 marked spots (right, left and in the middle).

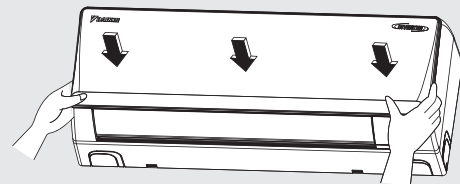
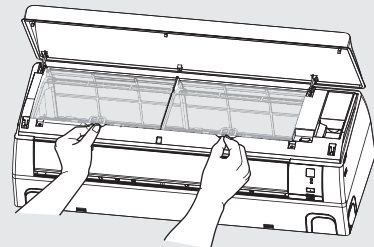

Air filters

Clean the air filters with vacuum cleaner or water.

- If the air filters are very dirty, please soak the air filters in warm water with neutral detergent and then dry it in the shade.
- It is recommended to clean the air filters every 2 weeks.

Product care

1. Vacuum the air filters and rinse it with water.
2. If the air filters are very dirty, please soak the air filters in water with neutral detergent for 10-15 minutes.
3. After washing, shake off the water and dry the air filters in the shade.

Care and Cleaning

⚠ CAUTION

- The unit can still operate with dirty filters but:
 - (1) it may not be able to generate clean air.
 - (2) the cooling performance may be affected.
 - (3) it may cause unpleasant odour.
 - (4) it may cause discolouration of the air filter.
- Please contact sales engineers if you want to order new air filters.
- Air filters are non-flammable. Please dispose of them properly.

It is recommended to inspect your unit regularly

- Check the stand, mount, and other fittings of the outdoor unit for any sign of decay or corrosion.
- Check that the air inlet and the outlet of the indoor unit and the outdoor unit are not blocked.
- Check that the water comes out from the drain hose smoothly in COOL, DRY, CLEAN operation.
 - Clogged draining may cause water leaking from the indoor unit. Please stop using the unit immediately and consult sales engineers.

If the unit is not in use for an extended period

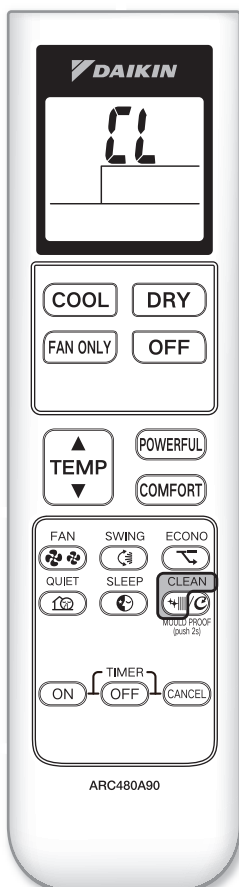

1 Run CLEAN operation for 2 hours on a sunny day to clean the heat exchanger of the indoor unit.

- See P.20.

2 Once the operation stops, turn off the power of the indoor unit.

3 Reinstall the air filters after cleaning.

- See P.29.

4 Take out the batteries from the remote controller.

FAQs

Not trouble You can still use the unit in the following cases, which are not troubles.

Case	Description
<p>The operation does not start immediately</p> <ul style="list-style-type: none"> • When the operation is restarted shortly after it stops running. • When another operation mode is selected. 	<ul style="list-style-type: none"> • To protect the air conditioner, please stop using the unit for 3 minutes before restarting it.
<p>Water or steam comes out from the outdoor unit.</p>	<p>■ In COOL, DRY or CLEAN operation</p> <ul style="list-style-type: none"> • Moisture in the air condenses on the refrigerant pipe of the outdoor unit and drips.
<p>Mist comes out from the indoor unit.</p>	<ul style="list-style-type: none"> • Mist occurs when the air in the room is cooled by the cold airflow in the COOL operation. • Mist occurs when the air in the room is cooled by the cold airflow in the CLEAN operation.
<p>The air conditioner gives out an unpleasant odour.</p>	<ul style="list-style-type: none"> • This happens when the smells of the room, furniture or cigarettes are absorbed by the indoor unit and discharged into the air (it is recommended to contact professional technicians to clean the indoor unit).
<p>The fan of the outdoor unit rotates even when the unit is not in operation.</p>	<p>■ Immediately after the air conditioner is stopped</p> <ul style="list-style-type: none"> • The outdoor unit fan continues rotating for about 60 seconds to protect the system. <p>■ While the air conditioner is not in operation</p> <ul style="list-style-type: none"> • When the outdoor temperature is high, the outdoor unit fan may start rotating to protect the system. 
<p>The operation stops suddenly (the OPERATION lamp is on).</p>	<ul style="list-style-type: none"> • To protect the system, the air conditioner may stop operating after sudden large voltage fluctuations. It automatically resumes operation in about 3 minutes.
<p>The indoor unit does not receive signals from the remote controller; the remote controller sensitivity is low; the remote controller display is faint, not working, or erratic.</p>	<ul style="list-style-type: none"> • Malfunction may be caused by the exhaustion of remote controller batteries. Replace both batteries with new dry batteries (refer to P.11 for details). ※ Press the reset button if available after replacing the batteries.

Not trouble

FAQs

Check

Please check again before requesting repairs.

Case	What to check
<p>The air conditioner does not work (the OPERATION lamp is off).</p> 	<ul style="list-style-type: none"> • Is the power turned off or the fuse blown? • Is there a power failure? • Are the batteries set in the remote controller? • Is the timer setting correct?
<p>The cooling performance is poor.</p>	<ul style="list-style-type: none"> • Are the air filters clean? • Is the air inlet or outlet of the indoor and outdoor units blocked? • Is the temperature setting appropriate? • Are the windows and doors closed? • Are the airflow rate and airflow direction setting appropriate?
<p>The operation stops suddenly (the OPERATION lamp flashes).</p>	<ul style="list-style-type: none"> • Are the air filters clean? • Is the air inlet or outlet of the indoor and outdoor units blocked? <p>Turn off the power supply, then clean the air filters or remove any obstacles. After connecting the power supply, restart the air conditioner using the remote controller. If the OPERATION lamp continues to flash, please contact sales engineers.</p>
<p>An abnormality occurs during operation.</p>	<ul style="list-style-type: none"> • If the power supply is unstable or there are radio waves nearby, the operation may be affected. Turn off the power supply and turn it on again. Restart the unit with the remote controller.
<p>The indoor unit keeps running even after the operation is stopped.</p>	<ul style="list-style-type: none"> • Is the MOULD PROOF operation in operation? <p>In the MOULD PROOF operation, the OPERATION lamp will turn off and the fan of the indoor unit will keep running.</p>

Check again

Troubleshooting

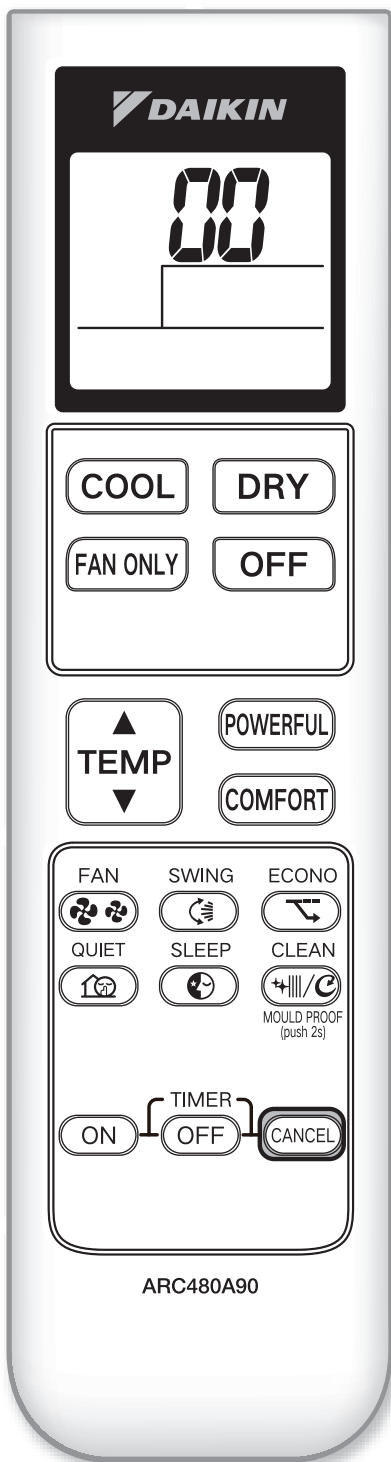

ARC480A90

Description

- A short beep and two consecutive beeps indicate different codes.
- To cancel the code display, hold "Cancel timer" for 5 seconds. The code display also clears if no button is pressed for 1 minute.

Troubleshooting

Troubleshooting with the remote controller

■ You can check the code displayed on the temperature display of the remote controller ARC480A90 (white).

1 Press and hold "CANCEL" for 5 seconds. "00" will flash on the temperature display.

2 Press "CANCEL" repeatedly until you hear a long beep.

- The code changes as shown below and will give out a long beep as a notification.

	CODE	MEANING
SYSTEM	00	NORMAL
	UA	INDOOR AND OUTDOOR UNIT COMBINATION FAILURE
	U0	REFRIGERANT SHORTAGE
	U2	DROP VOLTAGE OR MAIN CIRCUIT OVERVOLTAGE
	U4	FAILURE OF TRANSMISSION (BETWEEN INDOOR UNIT AND OUTDOOR UNIT)
INDOOR UNIT	A1	INDOOR PCB DEFECTIVENESS
	A5	HIGH PRESSURE CONTROL OR FREEZE-UP PROTECTOR
	A6	FAN MOTOR FAULT
	C4	FAULTY HEAT EXCHANGER TEMPERATURE SENSOR
	C9	FAULTY SUCTION AIR TEMPERATURE SENSOR
OUTDOOR UNIT	E1	CIRCUIT BOARD FAULT
	E5	OL STARTED
	E6	FAULTY COMPRESSOR START UP
	E7	DC FAN MOTOR FAULT
	F3	HIGH TEMPERATURE DISCHARGE PIPE CONTROL
	F6	HIGH PRESSURE CONTROL (IN COOLING)
	H0	SENSOR FAULT
	H6	OPERATION HALT DUE TO FAULTY POSITION DETECTION SENSOR
	H8	DC CURRENT SENSOR FAULT
	H9	FAULTY SUCTION AIR TEMPERATURE SENSOR
	J3	FAULTY DISCHARGE PIPE TEMPERATURE SENSOR
	J6	FAULTY HEAT EXCHANGER TEMPERATURE SENSOR
	L3	ELECTRICAL PARTS HEAT FAULT
	L4	HIGH TEMPERATURE AT INVERTER CIRCUIT HEATSINK
	L5	OUTPUT OVERCURRENT
	P4	FAULTY INVERTER CIRCUIT HEATSINK TEMPERATURE SENSOR

Please contact sales engineers immediately

WARNING

■ **Stop using the unit immediately and turn off the power if an abnormality (e.g., a burning smell) is detected.**

Operating the unit when an abnormality occurs may cause malfunction, electric shock, fire.

Please contact sales engineers for assistance.

■ **Do not attempt to repair or modify the unit as**

This may result in electric shock or fire.

Please contact sales engineers for assistance.

Please contact sales engineers immediately if any of the following occurs.

- The power cable is abnormally hot or damaged.
- The unit gives out abnormal sound during operation.
- The circuit breaker, the fuse or the earth leakage circuit breaker trips or blows.
- The switch or button does not work properly.
- There is a burning smell.
- Water leaks from the indoor unit.

Turn off the power and contact sales engineers for assistance.

After a power failure

The air conditioner will automatically resume operation in 3 minutes after connecting to power supply. Please wait patiently.

Lightning

If there is a risk lightning could strike in the neighbourhood, stop operation, and turn off the power to protect the system.

Regular maintenance is recommended



The air conditioner will become dirty after being used for seasons, subject to the frequency of use, resulting in poorer performance. You should clean the unit and request for professional care regularly. Please contact sales engineers for professional service.

The fees for professional care should be borne by you.





Safety Precautions for Installation

 Read the precautions in this manual carefully before operating the unit.	 Mildly flammable.
--	---

- The precautions described herein are classified as WARNING and CAUTION. They both contain important information regarding safety. Be sure to observe all precautions without fail.
- Meaning of WARNING and CAUTION notices.

 WARNING	Failure to follow these instructions properly may result in personal injury or loss of life.
 CAUTION	Failure to observe these instructions properly may result in property damage or personal injury, which may be serious depending on the circumstances.

- The safety marks shown in this manual have the following meanings:

 Be sure to follow the instructions.	 Be sure to establish an earth connection.	 Never attempt.	 Mildly flammable.
---	---	--	---

- After completing installation, conduct a trial operation to check for faults and explain to the customer how to operate the air conditioner and take care of it with the aid of operation manual.

WARNING

Important

- This air conditioner is charged with R32 refrigerant. Improper handling may result in personal injury or property damage. Please read the manual carefully before installing, using, or repairing the unit.
- A leakage test must be carried out after installation to ensure that there is no refrigerant leak.
- For R32 refrigerant, the air must be discharged with a vacuum pump.
- Do not let gases other than R32 get in the cooling system when installing, moving, or repairing the unit.
- Never have an open flame or ignition source in areas where R32 refrigerant is present.
- Antistatic measures should be taken when installing the air conditioner.
- If R32 refrigerant leak is detected during installation, please open all doors and windows immediately to improve ventilation. Everyone should leave the room and wait until the refrigerant dissipates. If the unit is damaged, please send it back for repair. No welding of the refrigerant pipe should be carried out on site.
- Do not attempt to install the unit. Please contact qualified technicians for installation. Improper installation may result in water leak, electric shocks, or fire.
- Please install the unit in strict compliance with this operation and installation manual. Improper installation may result in water leak, electric shock, or fire.
- Please use the accessories provided with the unit and designated parts. Using other parts may cause the air conditioner to fall or result in water leak, electric shock, or fire.
- Install the unit in a place that can support the weight. If the unit is not installed properly or the mount is not strong enough, the air conditioner may fall and cause injury.
- Please carry out the wiring work following the precautions contained in this operation and installation manual, relevant wiring regulations, or the specifications. Power cable of inadequate capacity or improper wiring may result in electric shock or fire.
- Use separate cable dedicated to the air conditioner. Do not share cables with other appliances.
- Do not use cables with connectors or extension cords or connect other loads. Please use separate cable dedicated to the air conditioner. Violating the precautions above may result in overloading, electric shock, or fire.
- Use designated cable to connect the indoor and outdoor units. Secure the cable to avoid unnecessary force on the terminal. Improper or insecure connection may result in overheating of the terminal or fire.

Unbox the air conditioner

- The air conditioner should be unboxed in a well-ventilated spot (a room with open doors and windows, open balconies, a well-ventilated staircase, etc). There should be no heat source or open flames nearby.
- Please check if there is any refrigerant leak before unboxing the outdoor unit; if there is, do not install the unit.

Inspect the installation spot

- Before installation, please ensure that the room meets the installation requirements. The room should not be smaller than the minimum space required for installation. If this happens, you should explain the situation to the user and decline the installation request.
- Before installation, please ensure that there are no flammable substances nearby or a fire is unlikely to occur. The unit cannot be installed in a confined space.
- The installation site should be well ventilated (open the doors and windows).
- Make sure that the power cords and cables of the indoor and outdoor units are properly installed and connected so that the lid of the electrical parts compartment can close perfectly. A loose lid may result in overheating of the terminal, electric shock, or fire.
- When recovering the refrigerant, please stop the compressor before removing the refrigerant pipe. If the compressor is still operating and the stop valve is open during refrigerant recovery, air embolism may occur when removing the refrigerant pipe, stressing, and cracking the refrigerant circuit and resulting in personal injury.
- When installing the unit, make sure to connect the refrigerant pipe before switching on the air conditioner. If the refrigerant pipe is not connected and the stop valve is open when the compressor starts running, air embolism may occur, stressing and cracking the refrigerant circuit and resulting in personal injury.
- An earthing wire must be installed. Do not connect the earthing wire to a gas pipe, water pipe, lightning  rod, or a telephone earthing line. Improper earthing may result in electric shock or fire. Machine failure may occur due to surge currents such as lightning.
- Install a residual current device according to the environment to prevent electric shock. Failure to install a residual current device may result in electric shock or fire.
- Install the indoor unit at least 1.8m above the ground. Systems with total refrigerant charge lower than 1.84kg are not subjected to any room area requirements.

CAUTION

- Do not install the air conditioner if there is a flammable gas leak.  When flammable gas leaks and accumulates around the air conditioner, it may cause a fire.
- Install the drain pipe in accordance with this installation manual. Improper installation may result in water leak.
- Precautions for the installation of the outdoor unit. In cold regions where the outdoor temperature falls below or near freezing point for extended periods, the water discharged from the outdoor unit may freeze. In this case, it is recommended to install an electric heater to prevent the water from freezing.
- Tighten the flare nut with a torque wrench as instructed. Over-tightening may damage the flare nut after prolonged use and result in refrigerant leak.
- When installing the indoor unit, the panel and grille should avoid contact with the floor or other hard objects. When the unit is turned upside down for pipe connection, please take proper measures to protect the panel and grille. Protect the panel and grille from scratches.
- Do not install the outdoor unit in places where small animals live. Any leaves or small animals entering the unit and coming into contact with the electrical parts may cause machine failure, smoke or fire. Keep the space around the outdoor unit clear.
- Do not press the top of the outdoor unit while moving it. Sharp metal edges may cause injury.
- Due to the high temperature generated during the refrigeration cycle, please keep the wires and cables away from uninsulated pipes. Violating the instructions may result in overheating of wires and cables, electric shock or fire.
- To protect the environment and safeguard the health and safety of human and animals, do not discharge the refrigerant into the atmosphere. The refrigerant must be recovered using specialised equipment.

Accessories

■ Indoor unit accessories

Ⓐ Mounting plate	1	Ⓔ Operation and Installation Manual	1
Ⓑ Fixing screws for mounting plate M4×25L	7	Ⓕ Remote controller holder	1
Ⓒ Wireless remote controller	1	Ⓖ Fixing screws for remote controller holder M3×20L	2
Ⓓ AAA dry-cell battery	2		
Ⓔ Insulation tape	1	Ⓗ Indoor unit fixing screws M4×12L	2

Installation Sites

- The installation site should be determined with the consent of the user.

1 Indoor unit

- The indoor unit should be installed in a place where:
 - 1) The requirements specified in the installation drawings are met.
 - 2) The air inlet and outlet are not blocked.
 - 3) The unit is not exposed to direct sunlight.
 - 4) The unit is away from heat or steam source.
 - 5) No evaporation of machine oil occurs as it may shorten the lifespan of the indoor unit.
 - 6) Cool air circulates throughout the room.
 - 7) The unit is away from fluorescent lamps with electronic ignitors (such as fluorescent lamps with rectifiers) as it may shorten the transmission distance of the remote controller.
 - 8) The unit is at least 1m away from the TV or radio to avoid image distortion or electromagnetic interference.
 - 9) The top front of and the space under the indoor unit are not blocked to ensure optimal performance of the COMFORT AIRFLOW operation.
 - 10) The unit is not blocked by any metal objects as the wireless signals may be intervened.

2 Outdoor unit

- The outdoor unit should be installed in a place where:
 - 1) it is sturdy enough to support the weight and vibration of the outdoor unit without amplifying the operation sound.

- 2) the heat discharged from the outdoor unit or the operation noise will not disturb your neighbours.
- 3) the bedroom is away from the unit to minimise the disturbance caused by the operation sound at night.
- 4) there is sufficient space for moving the outdoor unit in and out.
- 5) it is well-ventilated and the air inlet and outlet are not blocked.
- 6) there is a risk of flammable gas leak.
- 7) the indoor and outdoor units, power cord, cables, and wires are at least 3m away from the TV, antenna, or radio to minimise the interference with the reception of image and sound (there may still be some noise beyond this distance, subject to the strength of radio waves).
- 8) it is not a coastal area or any other areas with higher concentrations of salt or sulfurized gases in the air as corrosion may shorten the lifespan of the unit.
- 9) no objects that are easily damaged by moisture are placed directly beneath the outdoor unit, as water may be discharged.

CAUTION

Do not suspend the outdoor unit from the ceiling or place any objects on top.

⚠ CAUTION

Please observe the following precautions if the air conditioner is installed in places where the temperature is low:

- 1) Install the outdoor unit with the air inlet facing the wall to avoid exposure to strong winds.
- 2) Do not install the outdoor unit in places where the air inlet may be exposed to strong winds.
- 3) Install a wind shield at the air outlet of the outdoor unit to avoid exposure to strong winds.
- 4) In snowy areas, install the air conditioner in places where the outdoor unit will not be covered in snow.



■ The space required for the installation of the outdoor unit

- If there are any obstacles on the walls near the air inlet and outlet of the outdoor unit, please install the air conditioner as follows.
- No matter how the air conditioner is installed, the height of the wall faced by the air outlet should not exceed 1,200mm.

Model 25/35

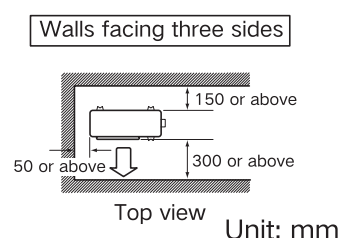
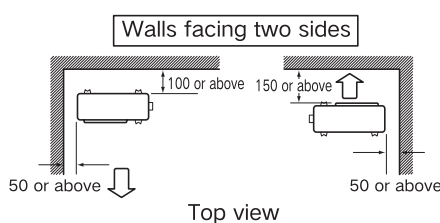
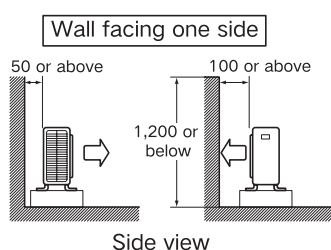

Model 50/60/71

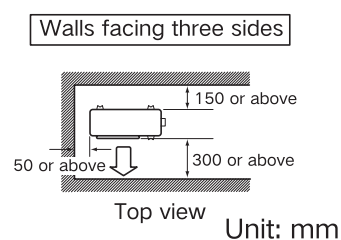
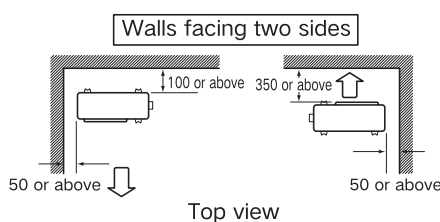
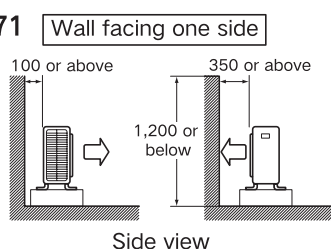

■ Precautions for the installation of the outdoor unit

- Make sure the installation spot is sturdy and level to minimise the operation noise and vibration after the unit is installed.
- Secure the unit to the stand with mounting screws following the installation drawings (prepare four sets of M8 or M10 mounting screws, nuts, and base leg vibration pads, which are available on the market).
- Tighten the screws until they are 20mm from the surface of the stand.

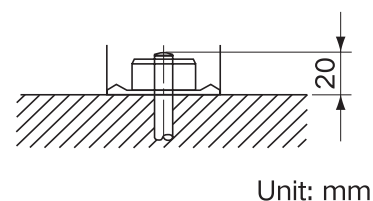

Indoor/outdoor units installation drawings

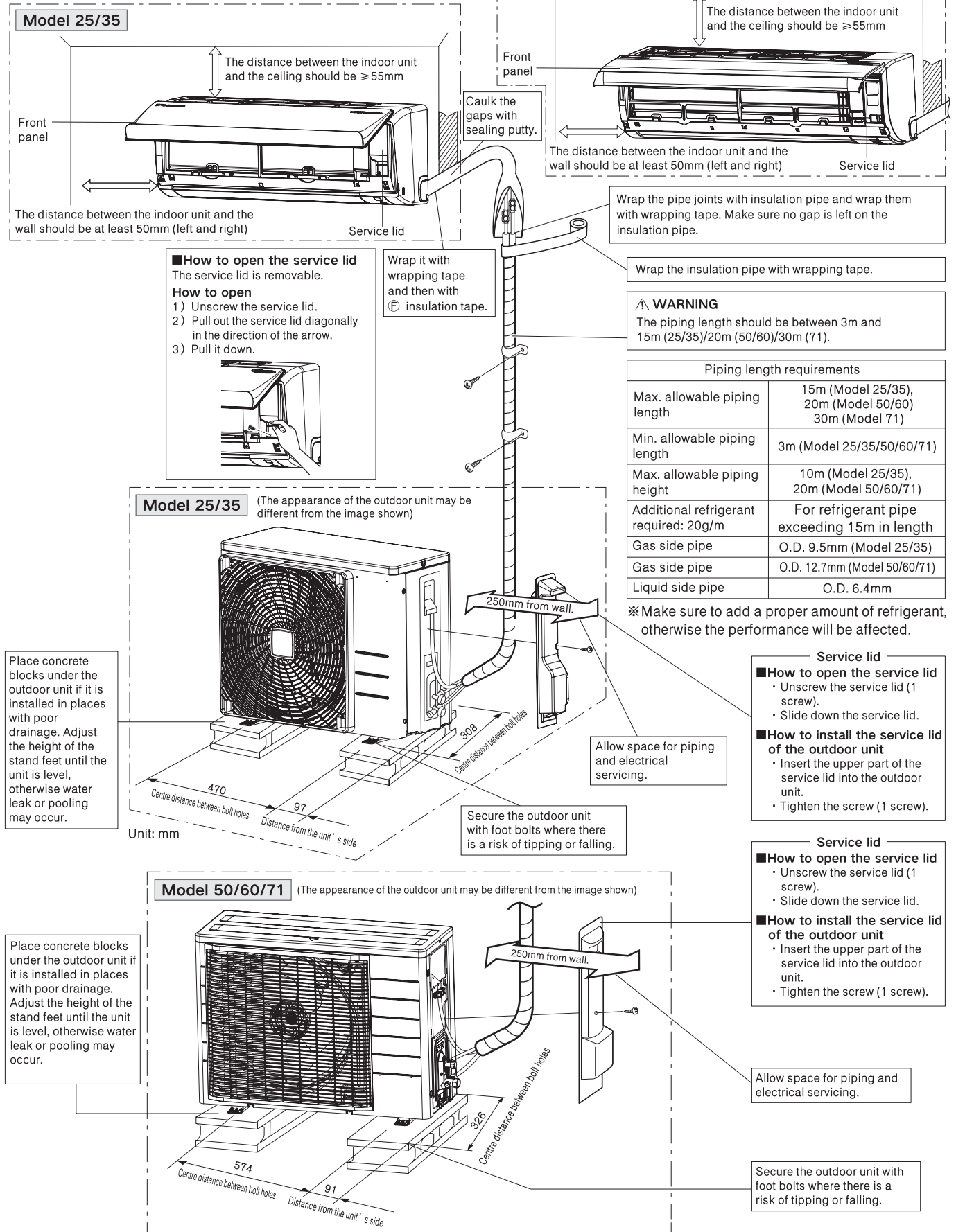

Precautions for Installation

1 How to remove and install the front grille

• To remove the front grille

- 1) Remove the front panel and air filters.
- 2) Remove the front grille.
- 3) There are hooks (3 hooks) on the top of the front grille with ○○○ mark. Gently pull out the front grille with one hand and press the hooks (3 hooks) down with the other hand.

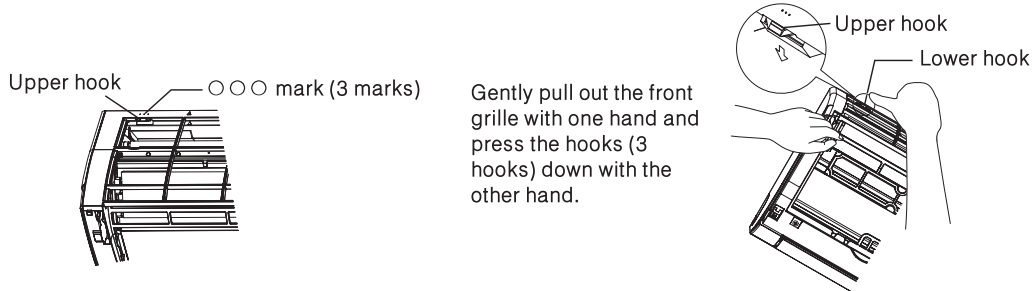

<When there is not sufficient working space as the unit is close to the ceiling>

⚠ CAUTION

Wear work gloves.

Reach into the gap in the middle of the front grille and pull it upwards and forwards at the same time.

• To install the front grille

- 1) Reinstall the front grille and secure the upper hooks (3 hooks).
- 2) Tighten the 2 screws of front grille.
- 3) Install the air filters and front panel.

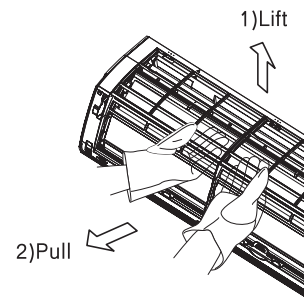

2 How to set different addresses

If two indoor units are installed in the same room, please change the address setting of one of the units.

Be careful not to damage the components when disconnecting the jumper.

- 1) Remove the battery cover of the remote controller and cut the address jumper.
- 2) Press TEMP▲, TEMP▼ and the POWERFUL buttons simultaneously.
- 3) Press▲ (increase temperature) to select “A”. Press the POWERFUL button to confirm. The indoor unit OPERATION lamp will start flashing (the OPERATION lamp will go off after 1 minute).
- 4) While the OPERATION lamp is flashing, press the ON/OFF button on the indoor unit to complete the setting.

- If the OPERATION lamp is off and the setting cannot be changed, please repeat the procedures above to restart.
- Once the setting is changed, the display of the remote controller will resume its original state if you press and hold “POWERFUL” for 5 seconds.

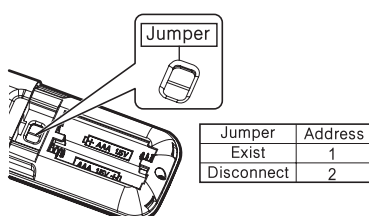

Model 25/35

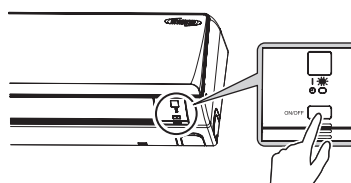

Model 50/60/71

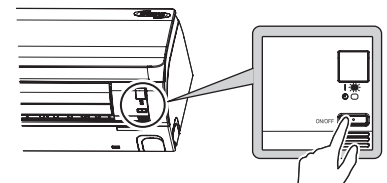

Installation of Refrigerant Pipe

1 Flaring the pipe end

- 1) Cut the pipe end with a pipe cutter.
- 2) Remove burrs with the cut surface facing downwards to prevent metal swarf or chips from entering the pipe.
- 3) Put the flare nut on the pipe.
- 4) Flare the pipe.
- 5) Check if the flaring is properly made.
- 6) Protect the pipe end properly against dust, dirt, and moisture.

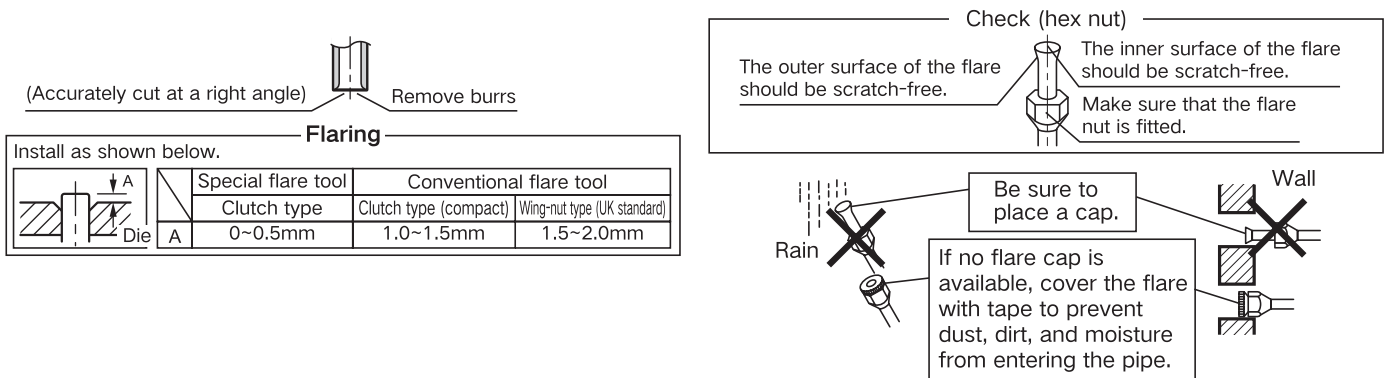

⚠ WARNING

- 1) Do not use mineral oil on the flare.
- 2) Prevent mineral oil from entering the system as this will shorten the lifespan of the air conditioner.
- 3) Never use used pipes. Only use the accessories provided with this air conditioner.
- 4) Never apply desiccants to the unit as this will shorten the lifespan of the air conditioner.
- 5) The desiccants may dissolve and damage the air conditioner.
- 6) Make sure that the flaring is properly made. Improper flaring may cause refrigerant leak.

2 Connection of refrigerant pipe

- 1) To prevent gas leak, apply refrigeration machine oil to the inner surface of the flare (use refrigeration machine oil for R32).
- 2) Align the centres of the refrigerant pipe and the flare. Tighten the flare nuts by hand for 3 to 4 turns and then secure them with a torque wrench.
 - Tighten the flare nuts with a torque wrench to prevent the connection from loosening or gas leaking.

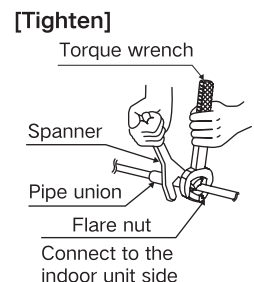
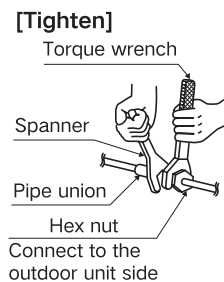
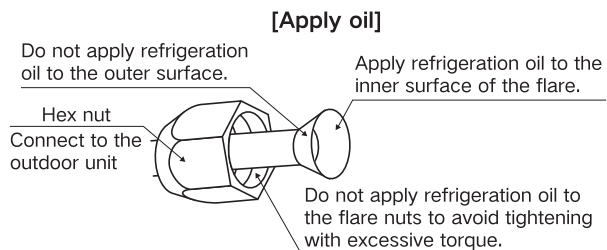

Torque for tightening flare nut		
Gas side		Liquid side pipe
Model 25/35	Model 50/60/71	
O.D. 3/8 "	O.D. 1/2 "	O.D. 1/4 "
32.7-39.9N · m (333-407kgf · cm)	49.5-60.3N · m (505-615kgf · cm)	14.2-17.2N · m (144-175kgf · cm)

Note: Make sure that the centres of the refrigerant pipe, the flare and the flare nut are aligned to avoid loosening or gas leaking.

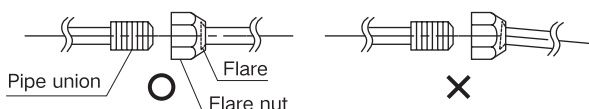

2-1. Precautions for piping

- 1) Prevent dust, dirt, or moisture from entering the pipes.
- 2) Please use a pipe bender for pipes with small curvature.
(The bend radius ranges from 30 to 40mm)

2-2. Selection of copper pipe and heat insulation materials

- Observe the following precautions when purchasing materials.

1) Insulation material: Polyethylene foam

Thermal conductivity: 0.041 to 0.052 W/m.K
(0.035 to 0.045 kcal/(mh · °C))

(Since the surface temperature of the gas pipes can reach up to 110°C, please choose a material that can withstand high temperature.)

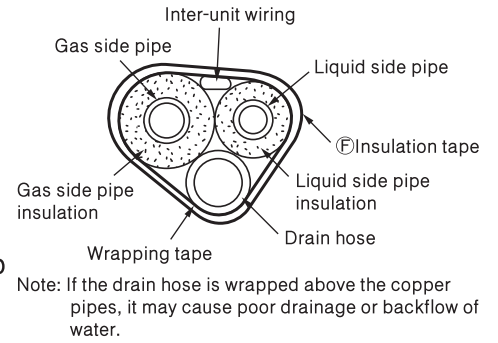

- 2) Make sure to use the insulation materials below to insulate the gas side and liquid side pipes.

Gas side		Liquid side	Gas side pipe insulation		Liquid side pipe insulation
Model 25/35	Model 50/60/71		Model 25/35	Model 50/60/71	
O.D. 9.5mm	O.D. 12.7mm	O.D. 6.4mm	I.D. 12~15mm	I.D. 14~16mm	I.D. 8~10mm
Minimum bend radius			Thickness of 10mm or more		
30mm or more	40mm or more	30mm or more			
Piping thickness 0.7mm (Model 25/35), 0.8mm (Model 50/60/71)					

- 3) Insulate the gas side and liquid side pipes separately.

3 Operating range

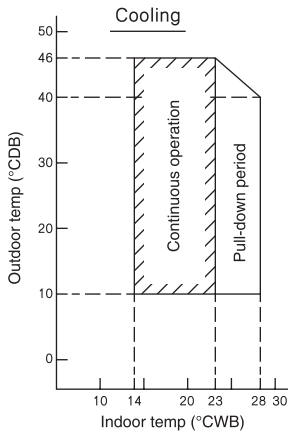

Installation of Indoor Unit

1 How to install the mounting plate

- The mounting plate should be installed on a wall which can support the weight of the indoor unit.

- 1) Temporarily secure the mounting plate to the wall, make sure that the panel is completely level, and mark the drilling points on the wall.
- 2) Secure the mounting plate to the wall.

Recommended spots and dimensions for mounting plate

Model 25/35

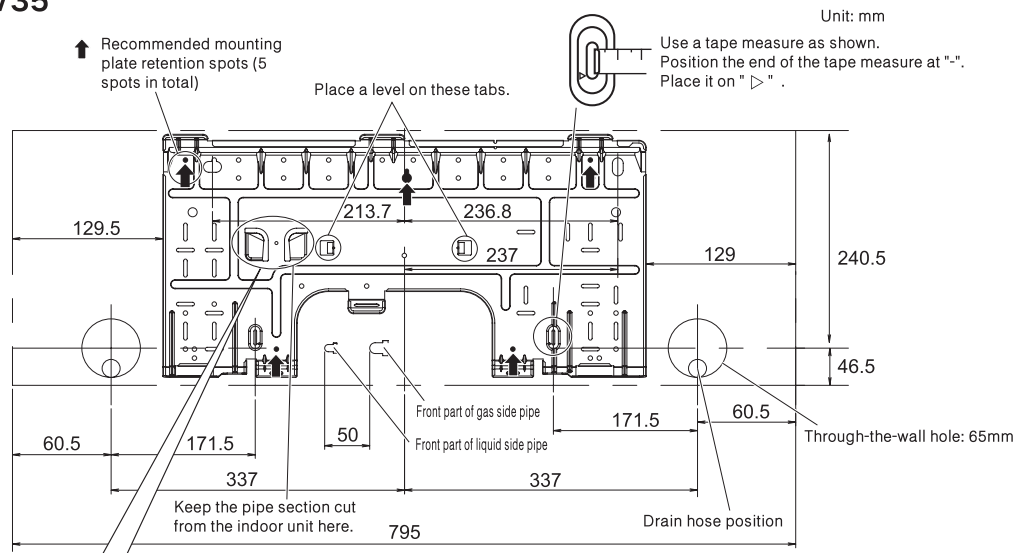

*The pipe section cut from the indoor unit should be kept intact on the mounting plate for future use during relocation or other necessary purposes.

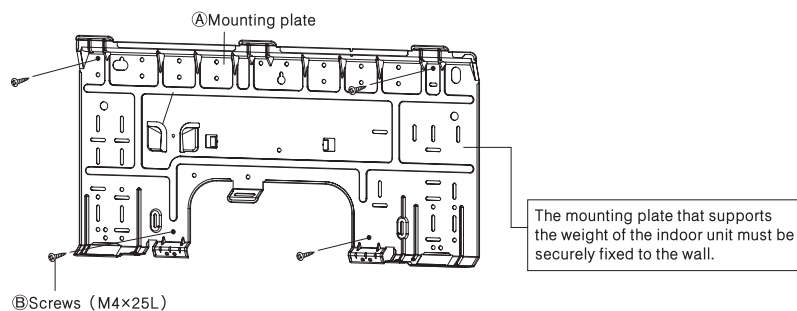
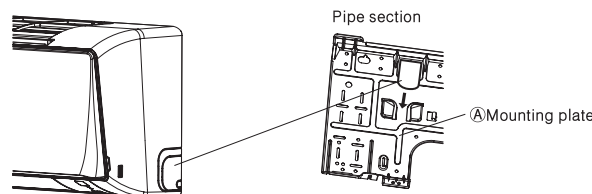

2 How to make a hole in the wall and install the wall penetration cap

- 1) For walls containing metal frame or metal board, be sure to use a wall penetration cap to prevent possible heat, electric shock, or fire.
- 2) Drill a feed-through hole of 65mm in the wall so it has a down slope towards the outside.
- 3) Insert the wall penetration cap into the drilled hole in the wall.
- 3) Caulk the gaps between the pipes, cables, and drain hose with sealing putty.

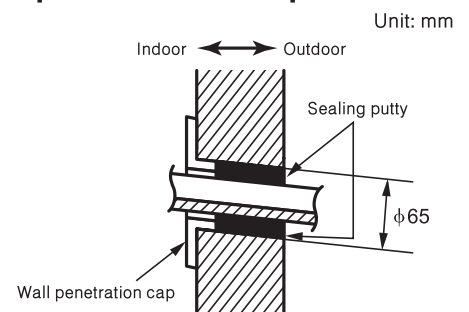

1 How to install the mounting plate

- The mounting plate should be installed on a wall which can support the weight of the indoor unit.

- 1) Temporarily secure the mounting plate to the wall, make sure that the panel is completely level, and mark the drilling points on the wall.
- 2) Secure the mounting plate to the wall.

Recommended spots and dimensions for mounting plate

Model 50/60/71

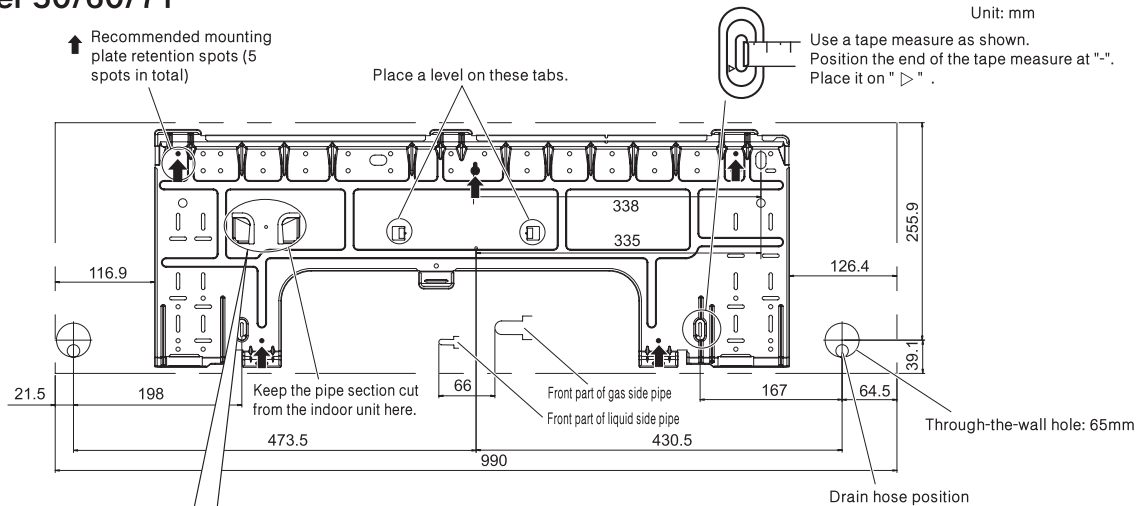

*The pipe section cut from the indoor unit should be kept intact on the mounting plate for future use during relocation or other necessary purposes.

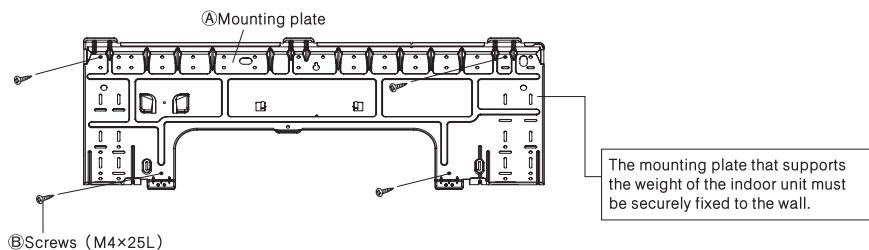
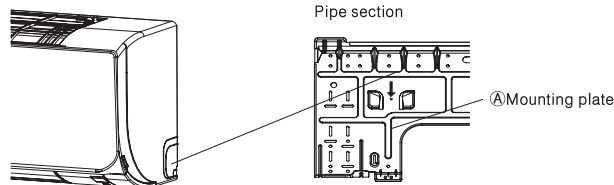

2 How to make a hole in the wall and install the wall penetration cap

- 1) For walls containing metal frame or metal board, be sure to use a wall penetration cap to prevent possible heat, electric shock, or fire.
- 2) Drill a feed-through hole of 65mm in the wall so it has a down slope towards the outside.
- 3) Insert the wall penetration cap into the drilled hole in the wall.
- 3) Caulk the gaps between the pipes, cables, and drain hose with sealing putty.

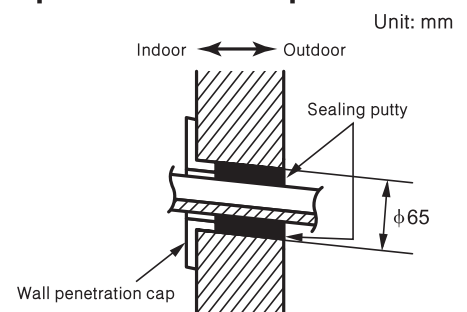

3 Installation of Indoor Unit

■ When bending and connecting the refrigerant pipe, please pay attention to the following:

Improper handling may cause abnormal sound.

- 1) Do not forcefully press the refrigerant pipe onto the bottom frame.
- 2) Do not forcefully press the refrigerant pipe onto the front grille.

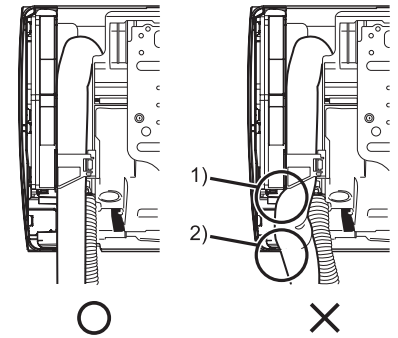

3-1. For right-side/right-back/right-bottom piping

- 1) Secure the drain hose to the bottom of the pipe with tape (carried by the installation personnel).
- 2) Wrap the refrigerant pipes and drain hose together with insulation tape.
- 3) Pass the drain hose and refrigerant pipes through the wall hole, then set the indoor unit on the mounting plate hooks by using the Δ mark at the top of the indoor unit as a guide.
- 4) Remove the front panel and open the service lid.
- 5) Pass the wire from the outdoor unit through the feed-through wall hole and then through the back of the indoor unit. Pull them through the front side. Bend the ends of cable tie wires upward for easier work in advance (if the wire ends are to be stripped first, bundle the wire lead ends with adhesive tape).
- 6) Press the bottom frame of the indoor unit with both hands to set it on the mounting plate hooks. Make sure the wire leads do not catch on the edge of the indoor unit.

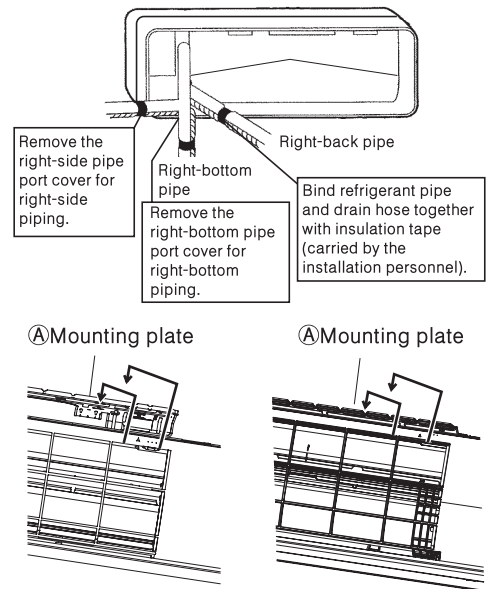

Model 25/35

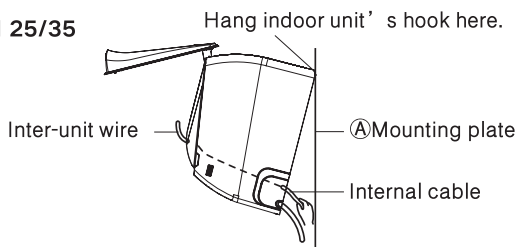

Model 50/60/71

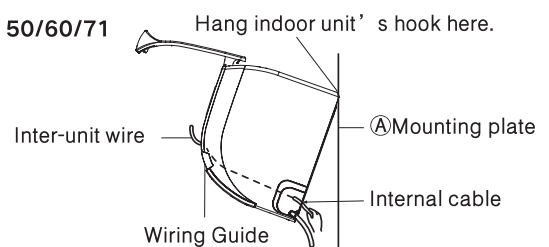

3-2. For left-side/ left-back/left-bottom left piping

How to move the drain plug and drain hose

• How to install on the left side

- 1) Unscrew the fixing screws for the insulation materials on the right side and remove the drain hose.
- 2) Tighten the fixing screws for the insulation materials on the right side in place as they were before.
 - *The absence of this part may result in water leak.
- 3) Remove the drain plug on the left side and attach it to the right side.
- 4) Insert the drain hose and secure it with the fixing screws for indoor unit.

Where to install the drain hose

*The drain hose is on the back of the air conditioner.
 ※ Image illustrated with model 25/35.

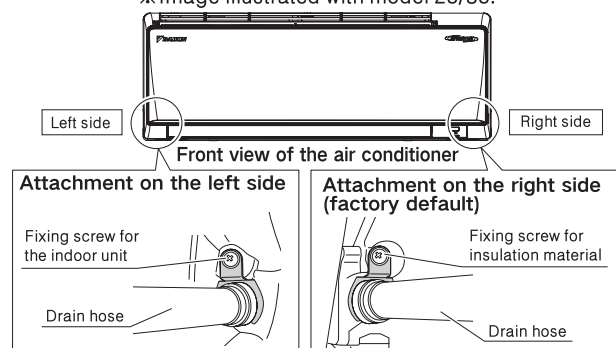

- 1) Secure the drain hose to the underside of the refrigerant pipes with tape (carried by the installation personnel).
- 2) Remove the drain plug from the drain-water hole and insert the drain hose.

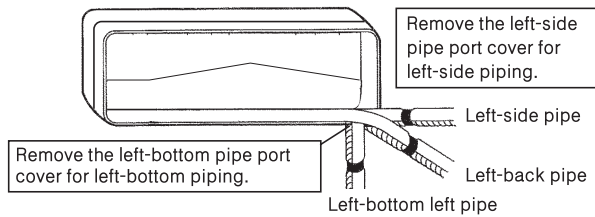

How to install the drain plug

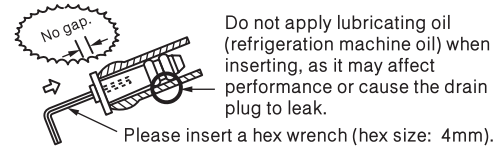

- 3) Pass the drain hose and refrigerant pipes through the wall hole, then set the indoor unit on the mounting plate hooks by using the Δ mark at the top of the indoor unit as a guide.

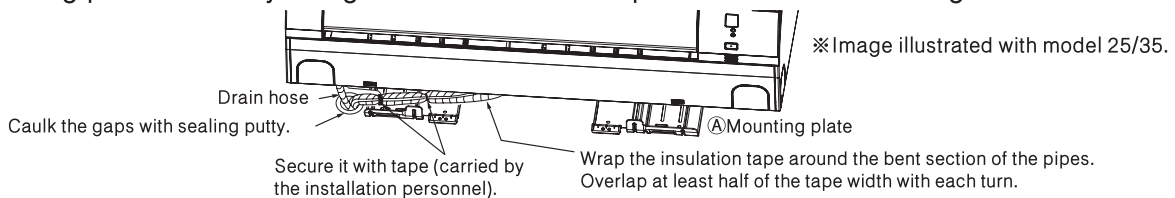

- 4) Pull in the inter-unit cable.
- 5) Remove the base cover and cut the pipe port cover to proceed to pipe connection.
- 6) Secure the refrigerant pipes and drain hose with wrapping tape.
- 7) Bind refrigerant pipes and drain hose together with insulation tape.
- 8) Avoid trapping the cables. Hold the lower end of the indoor unit with both hands and set it on the hooks of mounting plate (A). Secure the indoor unit to the mounting plate with the (K) indoor unit fixing screws (M4×12L).

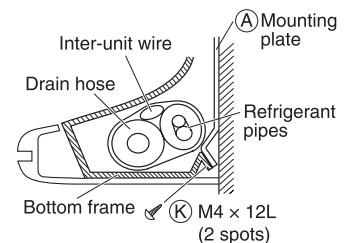

3-3. To embed the pipes

Follow the instructions under left-side/left-back/left-bottom left piping.

- 1) Insert the drain hose to this depth so it will not be pulled out of the drain pipe.

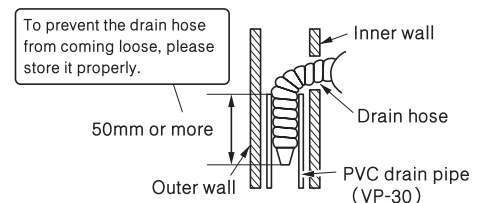

4 Wiring

- 1) Match the wire colours with the terminals on the indoor unit and screw the wires to the corresponding terminals.
- 2) Connect the earthing wire to the corresponding terminal block. The earthing wire should be under the live wire, neutral wire, and signal wire (as shown on the right). Do not touch the fan motor connector when connecting the earthing wire.

※ Image illustrated with model 25/35.

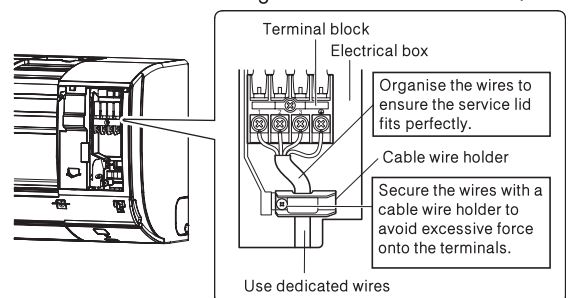

- 3) Pull the wires gently to make sure that the wires are securely fixed. Secure the wires with a wire stop.

Model 25/35

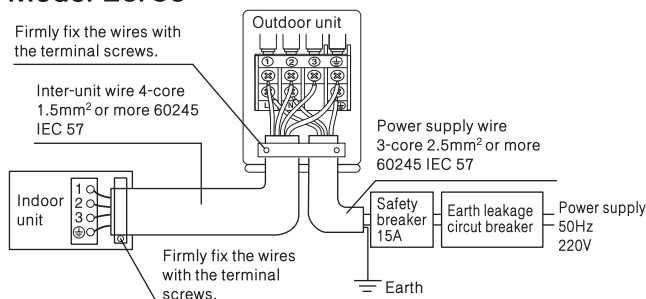

Model 50/60/71

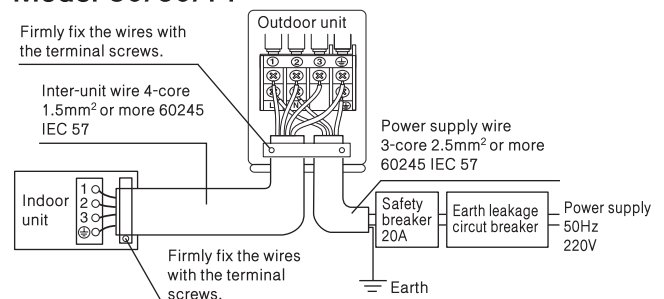

- 4) To ensure the service lid fits perfectly, please organise the wires and close the lid properly.
- 5) When connecting the inter-unit cable, please connect the earthing wire first before connecting a current carrying wire. When disconnecting the inter-unit cable, please disconnect the earthing wire after disconnecting the current carrying wire.
- 6) Secure the cable wire and earthing wire before switching on the power.

Note: The specifications of the fuse on the indoor unit circuit board:
T3.15A/250VAC (FU1)

⚠ WARNING: If the fuse is blown, please contact professional personnel for replacement. Do not attempt to replace it as improper replacement may result in electric shock.

⚠ WARNING

- 1) Do not use wires with connectors, extension cords or multi-core cables as they may cause overheating, electric shock, or fire.
- 2) Do not use the electrical parts that are not manufactured by our factory (do not branch power from the terminal block for the drain pump or other parts), as it may result in electric shock or fire.
- 3) Be sure to install a residual current device (compatible with high harmonic models). (To avoid machine failure, a residual current device compatible with high harmonic models must be installed as this unit comes with an inverter.)

5 Drain work

- 1) Pay extra attention to the drain work as described below.
- 2) Check the drain hose: Remove the air filters and pour some water into the drain pan to check the water flows smoothly.
- 3) When an extension of drain pipe is needed, you may get a drain hose extension from the market. Be sure to insulate the drain hose extension for the indoor unit.

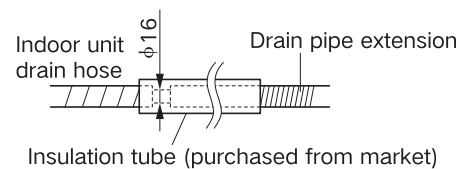
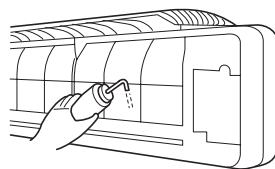
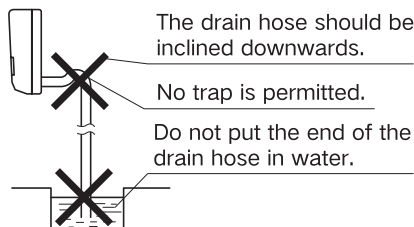

- 4) Please use a rigid PVC drain connector (16mm in nominal diameter) available on the market to connect the drain hose of the indoor unit to the rigid PVC pipe (16mm in nominal diameter).

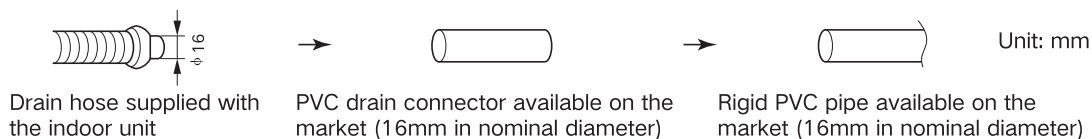

Installation of Outdoor Unit

1 Install the outdoor unit

- 1) Please refer to “Installation Sites” and the “Indoor/outdoor Units Installation Drawings” sections for the installation of the outdoor unit.

2 Wiring

⚠ WARNING

- 1) Do not use wires with connectors, extension cords or multi-core cables as they may cause overheating, electric shock, or fire.
- 2) Do not use the electrical parts that are not manufactured by our factory (do not branch power from the terminal block for the drain pump or other parts), as it may result in electric shock or fire.
- 3) Be sure to install a residual current device (compatible with high harmonic models).
(To avoid machine failure, a residual current device compatible with high harmonic models must be installed as this unit comes with an inverter.)
- 4) When connecting the inter-unit cable, please connect the earthing wire first before connecting a current carrying wire. When disconnecting the inter-unit cable, please disconnect the earthing wire after disconnecting the current carrying wire.
- 5) Secure the cable wire and earthing wire before switching on the power.

- Do not turn ON the safety breaker until all work is completed.

Observe the notes mentioned below when wiring to the power supply terminal board.

Precautions to be taken for power supply wiring.

- 1) Strip the insulation from the wire (20mm).
- 2) Connect the inter-unit wire between the indoor and outdoor units so that the terminal match.
Tighten the terminal screws securely. We recommend a flathead screwdriver be used to tighten the screws.
The screws are packed with the terminal board.
- 3) Pull the wire and make sure that it does not disconnect. Then fix the wire in place with a wire stop.

※The appearance of the terminal may be different from the image shown.

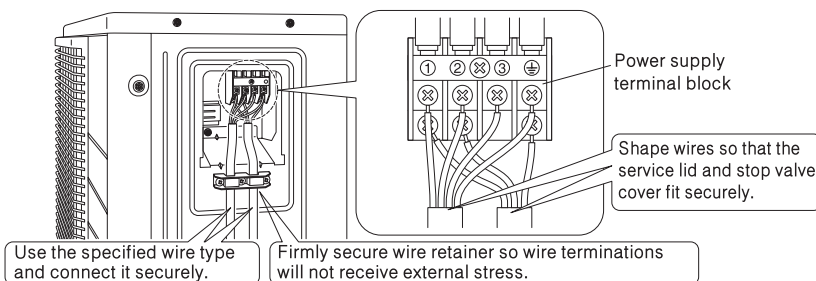

⚠ WARNING

Do not use wires with connectors, extension cords, or multi-core cables.
Using these cables may result in overheating, electric shock, or fire.

Note: The specifications of the fuse on the outdoor unit circuit board:
T3.15A/250VAC(FU1, FU2)
T20A/250VAC(FU3)(Model 25/35)
T30A/250VAC(FU3)(Model 50/60/71)

⚠ WARNING: If the fuse is blown, please contact professional personnel for replacement. Do not attempt to replace it as improper replacement may result in electric shock. Please pay attention to the following precautions when you connect the power terminal block and power cable.
(Connect the power terminal block with the round crimp-style terminal. Please observe the following precautions to avoid terminal failure due to unforeseeable factors.)

⚠ CAUTION

- Precautions to be taken for power supply wiring. When using stranded wires, make sure to use a round crimp-style terminal for connection to the power supply terminal block. Place the round crimp-style terminals on the wires up to the covered part and secure in place.
- When connecting the inter-unit wire to the terminal block using a single core wire, be sure to curl the end of the lead. Improper work may cause heat and fires.

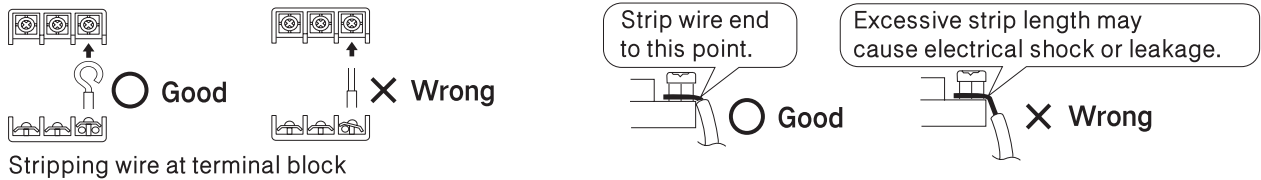

3 Air purging (evacuation) and gas leak check

- Once the pipes are properly installed, please purge the air and check for gas leak.

⚠ WARNING

- 1) Do not mix any gases other than the specified refrigerant (R32) into the refrigeration cycle.
- 2) If R32 refrigerant leak is detected during installation, please open all doors and windows immediately to improve ventilation. Please close the valve of the outdoor unit immediately. Everyone should leave the room.
- 3) For R32 refrigerant, the air must be discharged with a vacuum pump.
- 4) Use a vacuum pump for R32 exclusively. Using the same vacuum pump for different refrigerants may damage the vacuum pump or the unit.
- 5) Gas leak can be detected using a “bubble” test (with soap solution or bubble) or specific instrument. However, do not use a halogen sensor (or any other detectors with open flame).

- If using additional refrigerant, perform air purging from the refrigerant pipes and indoor unit using a vacuum pump, then charge additional refrigerant.
- Use a hex wrench (hex size: 4mm) to operate the stop valve rod.
- All refrigerant pipe joints should be tightened with a torque wrench at the specified tightening torque.

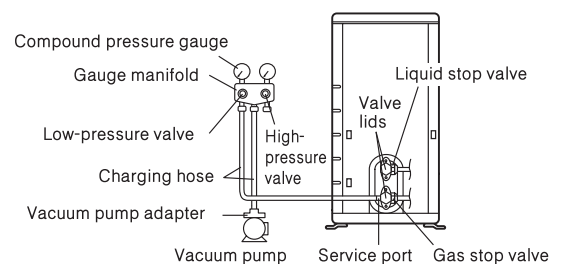

1. Connect the projection side of charging hose (which comes from gauge manifold) to gas stop valve's service port.
2. Fully open the gauge manifold's low-pressure valve (Lo) and completely close its high-pressure valve (Hi) (high-pressure valve subsequently requires no operation).
3. Start the vacuum pump and make sure that the compound pressure gauge reads -100KPa (-76cmHg) and the run time is not less than 15 minutes (model 25/35)/20 minutes (model 50/60/71).
4. Close the gauge manifold's low-pressure valve (Lo) and stop the vacuum pump. (Keep this state for 3-4 minutes (model 25/35) or 5-6 minutes (model 50/60/71) to make sure that the pointer of the compound pressure gauge does not swing back.) *1
5. Remove the covers from the liquid and gas stop valves.
6. Open the valve rod of the liquid stop valve by turning it 90° anticlockwise with a hex wrench. Close it after 5 seconds and check for gas leak. Wet the flares of the indoor and outdoor units and around the valve rod with soap solution to check for gas leak. Wipe clean after checking.
7. Detach the charging hose from the service port of the gas stop valve and then open the liquid and gas stop valves. (Tighten the valve rod until it stops. Do not overdo it.)
8. Tighten the nuts of the liquid and gas stop valves and the service port cap with a torque wrench at specified torques.

*1 If the compound pressure gauge pointer swings back, it may indicate the presence of water content in the refrigerant or the existence of a loose pipe joint. Check all pipe joints and retighten the nuts. Repeat steps 2 to 4.

4 Additional refrigerant charge

Check the type of refrigerant on the outdoor unit nameplate. (This unit is filled with R32 refrigerant.)

Precautions for additional R32 refrigerant charge

- Ensure that the charging equipment to be used is not contaminated by different refrigerants. Hoses or lines shall be as short as possible to minimise the amount of refrigerant contained in them.
- Cylinders shall be kept upright.
- Ensure that the refrigeration system is earthed before charging the system with refrigerant.
- Do not overfill the refrigeration system.

SPECIAL PRECAUTIONS WHEN DEALING WITH R32 UNIT

Models	The minimum installation height for indoor unit (m)	R32 charge, kg for 15m piping	R32 charge (20g/m), kg for max. allowable pipe length for (model 50/60/71) ³	Minimum floor area, (based on max. allowable pipe length) ⁴
FTKP25 - RKP25	1.8	0.50	-	Not applicable
FTKP35 - RKP35	1.8	0.60	-	
FTKP50/60 - RKP50/60	1.8	1.05	1.15	
FTKP71 - RKP71	1.8	1.15	1.45	

1. Calculation based on Installation Height of 1.8m.
2. Max. allowable length (L), m for:- 15m (model 25/35) / 20m (model 50/60) / 30m (model 71).
3. Additional refrigerant required: 20g/m for refrigerant pipe exceeding 15m in length.
4. Systems with total refrigerant charge lower than 1.84 kg are not subjected to any room area requirements.
5. Installation of pipe work shall be kept to minimum and pipe work shall be protected from physical damage and shall not be installed in an unventilated space.
6. Reusable mechanical connectors and flare joints shall be accessible for maintenance purposes.
7. Compliance with national gas regulations shall be observed.

IMPORTANT

Important information regarding the refrigerant used

This product contains fluorinated greenhouse gases. Do not vent gases into the atmosphere.

Refrigerant type: R32

Please fill in with inedible ink,

- ① the factory refrigerant charge of the product,
 - ② the additional refrigerant amount charged in the field and
 - ① + ② the total refrigerant charge
- on the refrigerant charge label supplied with the product. The filled out label must be adhered in the proximity of the product charging port (e.g. onto the inside of the service cover).

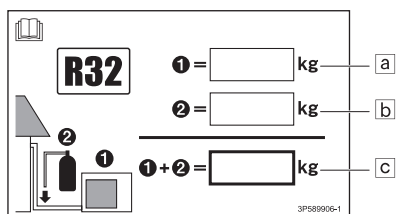

a Factory refrigerant charge: see unit name plate

b Additional refrigerant amount charged

c Total refrigerant charge

5 Refrigerant Pump Down Operation

To protect the environment and safeguard the health and safety of human and animals, the refrigerant must be pumped down back to the outdoor unit when relocating or disposing of the unit.

- 1) Remove the valve lids from the liquid and gas stop valves.
- 2) Carry out forced cooling operation.
- 3) After 5-10 minutes, close the liquid stop valve with a hex wrench.
- 4) After 2-3 minutes, close the gas stop valve and stop forced cooling operation.

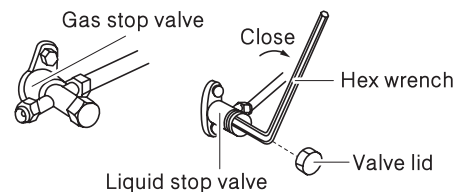

How to start forced cooling operation

■ Using the indoor unit ON/OFF switch

Press the indoor unit ON/OFF switch for at least 5 seconds (the operation will start).

- Forced cooling operation will stop automatically after around 15 minutes.

To stop the operation, press the indoor unit ON/OFF switch

⚠ CAUTION

- 1) Do not touch the terminal block while pressing the button as it contains high voltage and may cause electric shock.
- 2) Close the gas stop valve 3 minutes after closing the liquid stop valve and then stop the forced operation.

Test and Commissioning

1 Test and Commissioning

1-1. Measure the power supply voltage and make sure that it falls within the specified range.

1-2. Test and commissioning must be carried out for COOL operation.

• Please set the unit at the lowest temperature when testing the COOL operation .

1) After the test and commissioning, please set a moderate temperature (26-28°C in COOL operation).

2) To protect the unit, please wait for 3 minutes after turning off the unit before restarting it.

1-3. Conduct the trial operation in accordance with the precautions contained herein to make sure that all functions and parts are working properly.

• The air conditioner still consumes power even when it is not in use. Please turn off the power when the unit is left idle for an extended period to save energy.

• If the power supply is cut off during operation, the unit will restore the operation when the power supply is reconnected.

2 Test items

Test items	When a problem occurs (an error code is displayed on the remote controller)	Check
The indoor and outdoor units are properly mounted.	The unit falls off, vibrates, or gives out a noise	
There are no refrigerant leaks.	The unit is not cooling	
The pipes are thermally insulated (gas side and liquid side pipes and the drain hose extension of the indoor unit).	Water leak	
The drain pipes are properly installed.	Water leak	
The system is properly earthed and the earth terminals are tightened.	It would be dangerous when there is electrical leak	
The wires and cables are installed as instructed.	The unit is not running or blown	
The air inlet and outlet of the indoor and outdoor units are not blocked. The stop valves are fully open.	The unit is not cooling	
The wireless remote controller signal transmission is normal.	The unit is not running	

Precautions for repair and maintenance

WARNING

- The unit must be repaired or disposed of by qualified professionals.
- This unit is filled with R32 refrigerant. The unit must be repaired or disposed of in accordance with the national regulations and this manual.

Qualification requirements for technicians

- All technicians should obtain valid certificates issued by industry-recognised accreditation organisations to ensure that they are qualified to handle the refrigerant safely according to the recognised industry standards.
- Equipment should be maintained and repaired according to the methods recommended by the manufacturer. If assistance from other professionals is required for maintenance and repair works, it should be conducted under the supervision of qualified individuals with R32 refrigerant handling qualification.

Checking the area

Before repairing an air conditioner that uses R32 refrigerant, conduct safety checks to minimise the risk of ignition. When repairing the refrigerating system, take the following precautions before work.

Work procedures

Work shall be conducted under a controlled procedure so as to minimise the risk of working in the presence of flammable gases or vapour.

General working area

All maintenance staff and others working in the local area shall be instructed on the nature of work being carried out. Work in confined spaces shall be avoided.

The area around the workspace shall be sectioned off. Ensure that the conditions within the area have been made safe by control of flammable materials.

Checking for presence of refrigerant

The working area shall be checked with an appropriate refrigerant detector before and during work, to ensure the technician is aware of potentially flammable atmospheres. Ensure that the leak detection equipment being used is suitable for use with R32, i.e., non-sparking, adequately sealed or intrinsically safe.

Fire extinguishing equipment

If any hot work is to be conducted on the refrigeration equipment or any associated parts, appropriate fire extinguishing equipment shall be made available at hand. Prepare a dry powder or CO₂ fire extinguisher adjacent to the working area.

No ignition sources

During work on a refrigeration system which involves exposing any piping work that contains or has contained R32, any sources of ignition shall not be used in a manner that may lead to the risk of fire or explosion. All possible ignition sources, including cigarette smoking, should be kept at a safe distance from the site of installation, repairing, relocating, or disposal. Before starting work, the area around the equipment shall be examined to make sure that there are no flammable hazard or ignition risks. No Smoking signs shall be displayed.

Ventilated area

Ensure that the working area is open or that it is adequately ventilated before work. Adequate ventilation shall be maintained during the entire period of work. The ventilation should disperse any released refrigerant and preferably discharge it into the external atmosphere.

Checking the refrigeration equipment

Where electrical components are to be replaced, the new components should be installed properly in strict accordance with the specifications for their intended purposes. The manufacturer's maintenance and service guidelines shall be followed at all times. If anything is unclear, consult the manufacturer's technical department for assistance.

The following checks shall be applied to any installation work involving R32 refrigerant:

- The amount of charge is in accordance with the size of the room where the refrigerant containing parts are installed.
- The ventilation machinery and air outlets are operating properly and are not obstructed.
- If an indirect refrigerating circuit is being used, the secondary circuit shall be checked for the presence of refrigerant.
- Marking on the equipment is visible and legible. Markings and signs that are illegible shall be corrected.
- Refrigeration pipes or components are installed in a position where they are unlikely to be exposed to any substance which may corrode refrigerant containing components, or the refrigerant containing components are constructed of materials which are inherently resistant to corrosion or are suitably protected against corrosion.

Checking electrical devices

Repair and maintenance to electrical components shall include initial safety checks and component inspection procedures. In case there is any fault that could endanger safety, no electrical supply shall be connected to the circuit until the fault is satisfactorily dealt with.

Initial safety checks shall include:

- that capacitors are discharged: this shall be done in a safe manner to avoid potential risks of sparks;
- that no live electrical components and wiring are exposed while charging, recovering or purging the system;
- that the equipment is earthed at all times.

Repairs to sealed components

- During repairs to sealed components, all electrical supplies shall be disconnected from the equipment being worked upon before the removal of any sealed covers, etc. If it is absolutely necessary to have power supplied to equipment during servicing, leak detection should be carried out continuously for the high-risk parts to prevent potential hazardous consequences.
- Ensure that working on electrical components does not alter the casing in a way that affects the level of protection including damage to cables, excessive connections, terminals not installed as per specification, damage to seals, incorrect fitting of glands, etc.

Ensure that the equipment is mounted securely.

Ensure that seals or sealing materials have not degraded such that they no longer serve the purpose of preventing the ingress of flammable atmospheres. Replacement parts shall be in accordance with the manufacturer's specifications.

Note: The use of silicon sealant may inhibit the effectiveness of some types of leak detection equipment. Intrinsically safe components do not have to be isolated before working on them.

Repair to intrinsically safe components

Do not apply any permanent inductive or capacitance load to the circuit without ensuring that this will not exceed the permissible voltage and current for the equipment in use.

Only intrinsically safe components can be worked on in the presence of a flammable atmosphere. The test apparatus shall be of correct rating.

Replace components only with parts specified by the manufacturer. Using other parts may result in ignition of the refrigerant leaked into the atmosphere.

Wiring

Check that wiring is not subject to wear, corrosion, excessive pressure, vibration, sharp edges or any other adverse environmental effects. The check shall also take into account the effects of ageing or continuous vibration from sources such as compressors or fans.

Detecting of R32 refrigerant

Under no circumstances shall potential sources of ignition be used in the search for or detection of refrigerant leaks. A halogen sensor (or any other detector using an open flame) shall not be used.

Leak detection methods

The following leak detection methods can be applied for systems containing R32 refrigerant: Electronic leak detector can be used to detect R32 refrigerant, but the sensitivity may not be adequate or may need re-calibration (detection equipment shall be calibrated in a refrigerant-free area). Ensure that the detector is not a potential source of ignition and that it is suitable for the refrigerant used.

The leak detection equipment shall be set to the percentage of the lower flammability limit (LFL) of the refrigerant and calibrated to fit the refrigerant employed. The appropriate percentage of gas (maximum 25%) shall be confirmed.

Leak detection fluids are suitable for use with most refrigerants but the use of detergents containing chlorine shall be avoided as the chlorine may react with the refrigerant and corrode the copper piping work. If a leak is suspected, all open flames shall be removed or extinguished.

If a refrigerant leakage which requires brazing is found, all of the refrigerant shall be recovered from the system, or isolated (by means of stop valves) in a part of the system remote from the point of the leakage. Oxygen free nitrogen (OFN) shall then be purged through the system both before and during the brazing process.

Removal and evacuation

When breaking the refrigerant circuit to make repairs or any other purpose, conventional procedures may be used. However, flammability must be taken into consideration. The following procedure shall be adhered to:

- Remove refrigerant.
- Purge the circuit with inert gas.
- Evacuate the inert gas.
- Purge again with inert gas.
- Carry out cutting or brazing of the circuit.

The refrigerant shall be recovered into the correct recovery cylinders. The system shall be cleaned with OFN to render the unit safe. This process may need to be repeated several times. Compressed air or oxygen shall not be used for this task.

Flushing shall be achieved through breaking the vacuum by filling the system with OFN until the working pressure is achieved, then venting the OFN into the atmosphere, and finally pulling the system down to vacuum again. This process shall be repeated until no refrigerant remains within the system. After the last OFN charge is finished, the system shall be vented down to atmospheric pressure to enable work. This operation is especially important if brazing operations on the piping work are to take place.

Ensure that the outlet for the vacuum pump is not close to any ignition sources and that there is ventilation available.

Charging procedures

In addition to conventional charging procedures, the following requirements shall be met:

- Ensure that the charging equipment to be used is not contaminated by different refrigerants. Hoses or lines shall be as short as possible to minimise the amount of refrigerant contained in them.
- Cylinders shall be kept upright.
- Ensure that the refrigeration system is earthed before charging the system with refrigerant.
- Label the system when charging is complete (if not already).
- Do not overfill the refrigeration system.

Before recharging, the system shall be tested for leakage with OFN. On completion of charging, the system shall be tested before test and commissioning.

Follow up leakage test shall be carried out before leaving the site.

Decommissioning

Before carrying out this procedure, it is essential that the technician is completely familiar with the equipment and all its details. It is recommended to train technicians so that all of the refrigerant is recovered safely. In case analysis is required before re-using the reclaimed refrigerant, an oil and refrigerant sample shall be taken before proceeding with decommissioning. It is essential that electrical power is available before work.

1. Comprehend the equipment and its operation.
2. Isolate the system electrically.
3. Before starting work, ensure that:
 - mechanical handling equipment is available if required, for handling refrigerant cylinders;
 - protective equipment can be used in compliance with specifications;
 - the recovery process is supervised by a competent person at all times;
 - recovery equipment and cylinders conform to the appropriate standards.
4. Pump down the refrigerant system, if possible.
5. If vacuum cannot be ensured, apply a manifold so that refrigerant can be removed from various parts of the system.
6. Make sure that the cylinder has adequate capacity before the recovery process.
7. Start the refrigerant recovery device and operate it in accordance with the manufacturer's instructions.
8. Do not overfill cylinders (do not exceed 80% liquid charge volume).
9. Do not exceed the maximum working pressure of the cylinder, even temporarily.
10. When the cylinders have been filled correctly and the process is completed, make sure that the cylinders and the equipment are removed from site promptly and all valves on the equipment are closed.
11. Recovered refrigerant shall not be charged into another refrigeration system before it has been cleaned and checked.

Labelling

The equipment shall be labelled to indicate that it has been decommissioned and emptied of refrigerant. The label shall include the date and state that the equipment contains R32 refrigerant.

Recovery

When removing refrigerant from a system, either for servicing or decommissioning, it is recommended to conduct training so that all refrigerants can be removed safely.

When transferring refrigerant into cylinders, ensure that only appropriate refrigerant recovery cylinders are used. Ensure that the correct number of cylinders for holding the total system charge are available. All cylinders to be used must be designated for the recovered refrigerant and labelled for that refrigerant (i.e. special cylinders for the recovery of refrigerant). Cylinders shall be equipped with a pressure relief valve and associated stop valves in good working order. If possible, empty recovery cylinders shall be cooled in a separate place before recovery is conducted.

The recovery equipment shall be in good working order with instructions concerning the equipment at hand, and shall be suitable for the recovery of R32 refrigerant.

In addition, a set of calibrated weighing scales shall be available and in good working order.

Hoses shall be equipped with leak-free disconnect couplings and in good condition.

Before using the recovery device, check that it has undergone proper maintenance, that it is in satisfactory working order, and that any associated electrical components are sealed to prevent ignition in the event of a refrigerant leakage.

Consult manufacturer if in doubt.

The recovered refrigerant shall be returned to the refrigerant supplier in the correct recovery cylinder, with the relevant Waste Transfer Note attached. Do not mix refrigerants in recovery units and especially not in cylinders.

If compressors or compressor oil are to be removed, ensure that the refrigerant melted into the oil has been evacuated to an acceptable level to make certain that R32 refrigerant does not remain within the oil. The evacuation process shall be carried out before returning the compressor to the supplier. Only electric heating to the compressor body shall be employed to accelerate this process. Oil drained from the system shall be treated safely.

為了更好的體驗

定期清洗過濾網

- 過濾網上有積塵時，製冷效能會減弱。

▶ 83頁

不要在空調機周圍放置任何物品

- 會影響空調機效能或導致故障。

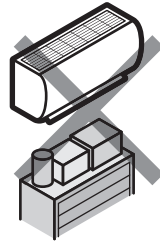

設定適當的溫度範圍

- 設定適當的溫度可以節省電力。

適當的溫度範圍
製冷時...26°C~28°C



定時器運轉

- 建議配合就寢及起床時間，設定時間掣控制空調機開關。定時開機和定時關機設定可同時使用。

▶ 81頁

長時間閒置時請切斷電源

- 空調機在不運轉時也要消耗2.0W的功率。當空調機長時間閒置時（如春季或秋季），請關閉電源。

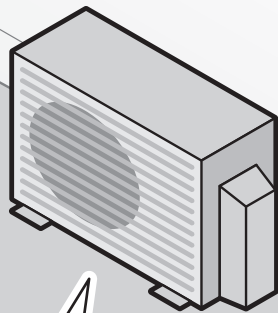

不要擋住回風口及出風口

- 會影響空調機效能或導致故障。



裝上百葉窗或窗簾

- 阻擋陽光或室外空氣，提升製冷效能。



目錄（使用）



安全注意事項	59
各部件的名稱和功能	61
運轉前的準備	65



智能控制	67
無線連接設定	67
除濕 / 製冷 / 送風運轉	69
風向調節	71



舒適氣流運轉	73
洗淨運轉	74
夜間睡眠運轉	75
強力運轉	76
節能模式	77
室外機靜音運轉	78
防霉運轉	79
定時器運轉	80



保養與清潔	82
-------	----



疑難排解	85
故障診斷	87

目錄（安裝）



安裝注意事項 89
配件確認 90







安裝地點 90
安裝注意事項 93
冷媒喉管安裝 94
室內機安裝說明 96
室外機安裝說明 101
試運轉 105
維修說明 106

安全注意事項

- 請將此說明書放在方便使用者查閱的地方。
- 在開始安裝、使用、維修空調機前，請先閱讀本說明書。
- 為了安全，請務必遵守下列注意事項。
- 本說明書的注意事項分為警告和注意兩個級別。它們都包含有關安全的重要信息，請嚴格遵守所有注意事項，以確保安全。

 警告 未能嚴格遵守這些指示可能會導致空調機嚴重損毀，甚至造成人命傷亡。	 注意 不正確的操作可能導致個人受傷、設備損毀或其他嚴重後果。
--	---

 切勿嘗試。	 必須遵守。
 必須接地。	 千萬不要弄濕空調機（包括遙控器）。
 千萬不要手濕時觸摸空調機（包括遙控器）。	



警告

 **切勿嘗試**

- 為了防止火災、爆炸或損傷，當空調機附近有可燃或腐蝕性氣體時，不得使用空調機。
- 長時間暴露於空調氣流中可能會影響健康。
- 禁止將手指、棒狀物或其他物體插入空調機的回風口或出風口。
- 禁止擅自維修、移動、改變或重新安裝空調機。若處理不當，可能會導致觸電、火災等。如需維修、重新安裝或遇到電源線損壞的情況，請與大金銷售工程師聯絡。

 **必須遵守**

- 如果空調機不能正常製冷，可能是冷媒洩漏，請與銷售工程師聯絡。完成維修或補充冷媒後，請向維修技術員了解維修詳情。
- 為了防止觸電、火災或受傷，一旦發現異常，例如聞到燒焦味等，請立即停止使用空調機和切斷電源，並與銷售工程師聯絡。
- 請根據環境安裝電源漏電斷路器（與高頻諧波型號兼容的），以避免觸電或火災。
- 空調機使用環保的R32冷媒，該冷媒無色無味，屬輕度易燃冷媒，燃燒等級為A2L。
- 空調機應放置在沒有持續熱源（例如明火、煤氣暖火機、煤氣爐、電子加熱器）的地方。
- 請勿刺破或點燃空調機。
- 除廠商制訂的方法外，不要用其他方法加快除霜過程或清潔結霜部份。
- 安裝高度必須離地板1.8m以上，總製冷劑充填量低於1.84kg的系統不受任何房間面積要求限制。
- 空調機應妥善存放，避免意外造成機器損毀。
- 應遵守有關氣體的法律與規例。
- 空調機應存放在通風良好的房間內，房間的面積必須符合本說明書的要求。
- 請勿擅自安裝空調機，安裝不當會導致漏水、觸電或火災。安裝、移裝、維修空調機前請聯絡銷售工程師，未經授權的人員不得進行此操作。
- 如需維修，請聯絡銷售工程師，並嚴格遵守廠家提供的操作手冊，禁止由非專業人士進行維修。
- 空調機必須由專業技術人員按相關規例和本說明書安裝、移機和維修。



 **必須接地**

- 空調機必須接地。接地不良會導致觸電，接地線不能接在煤氣管、水管、避雷針或電話的接地線上。

關於電氣工程

- 電源必須使空調機的獨立電源。

關於重新安裝設備

- 如因增建、翻新或搬遷緣故需要移動空調機，請聯絡銷售工程師，安排專業技術人員進行相關工程。

技術人員的資格

- 所有技術人員都應獲取行業認可的評估機構所頒發的有效證書，以確保他們能按照行業標準安全地處理冷媒。
- 只能按照設備製造商制訂的方法安裝、維修和保養設備，如需要其他專業人士協助安裝、維修和保養設備，應在合資格處理R32冷媒的人士監督下進行。

⚠ 注意



切勿嘗試

- 不要用空調來保存精密儀器、食物、植物、動物或藝術品，以免影響其品質。
- 不要讓幼兒、植物或動物直接暴露在空調機氣流下。
- 不要擋住出風口、回風口，以免影響效能或導致故障。
- 不要站在或坐在室外機上、在室外機上放置任何物品或拆去排風格柵，以免發生意外或受傷。
- 不要將易於受潮的物件放置於室內機或室外機之下，以免凝結的水珠破壞物件。
- 長時間使用後，請檢查空調機的底座和支架會否有損毀。
- 不要觸摸室外機回風口的鋁箔翅片，以免受傷。
- 空調機不可與其他電器共用電源，否則可能造成故障或引起火災。
- 本設備不可由兒童或智力不全者使用。
- 兒童必須在有人監護的情況下，方可使用本機，以確保他們不會把本空調機當作玩具。
- 不要在機器運轉時打開面板，以免發生意外或受傷。

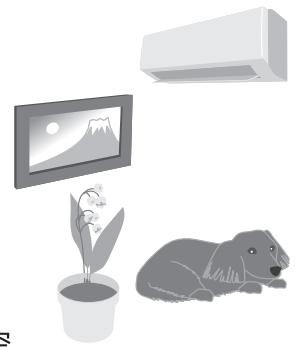

必須遵守

- 清洗空調機前，必須先停止空調機運轉，並關閉電源。
- 要確保排水軟管暢通，否則水或會滲到室內，弄濕家中的物件。
- 不要在室外機周圍堆積雜物、落葉等。一旦落葉、小動物等進入機器，接觸到內部電氣部件，會引致部件故障或冒煙、起火等情況。
- 為保護地球環境及保障安全，請不要於大氣排放冷媒。回收冷媒時必須使用專用的設備。



禁止濕手

- 不要手濕時操作空調機。



禁止受潮

- 不要用過多的水清洗室內機，只可用微濕的布拭擦機身。
- 不要將儲水的容器放在空調機上方，以免水份滲入空調機，降低電氣絕緣性，導致觸電。

關於安裝地點

- 如空調機安裝在以下地點，事前請諮詢銷售工程師。
 - 有油、蒸氣、煙的地方。
 - 沿海地區等空氣含鹽量高的地方。
 - 溫泉地區等有硫化氣體的地方。
 - 積雪會遮蓋室外機的地方。
- 室外機的排水口要設在容易排水的地方。

考慮運轉音量對鄰居的影響

- 請選擇符合以下條件的安裝地點。
 - 能承受空調機重量，而且不會擴大音量和增強震動的地方。
 - 室外機吹出的氣流和運轉音量不影響鄰居的地方。

各部件的名稱和功能

室內機

25/35機型

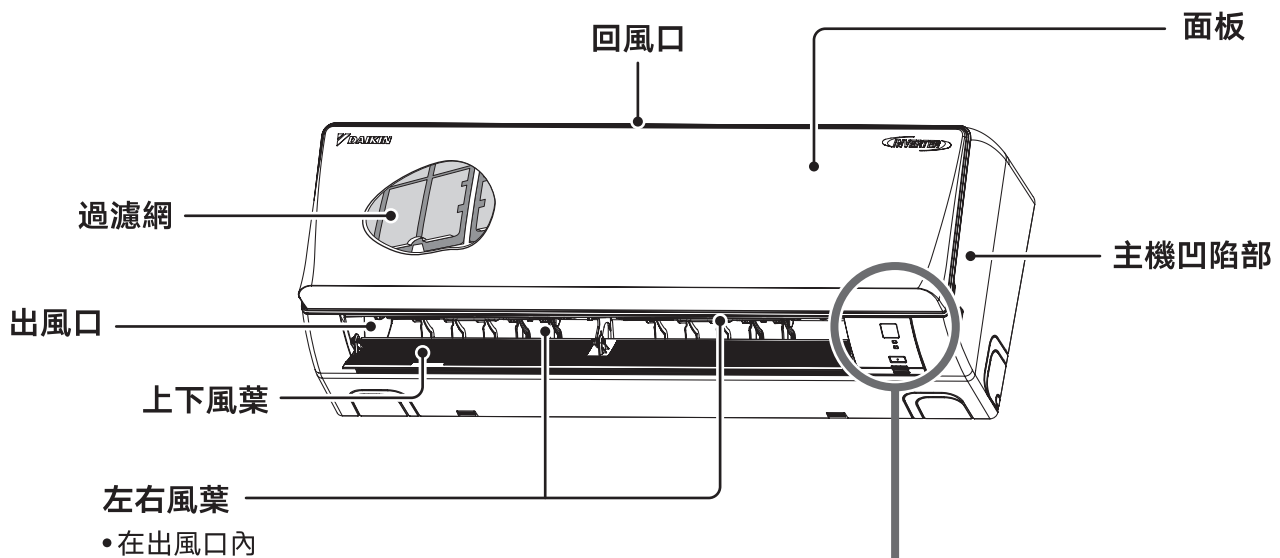

顯示

訊號接收器

- 接收遙控器發出的訊號。
- 一接收到訊號，會發出「嗶」聲，確認已收到訊號。
- 開始運轉：嗶嗶
- 改變設定：嗶
- 停止運轉：嗶—

室內溫度傳感器

- 偵測室內溫度

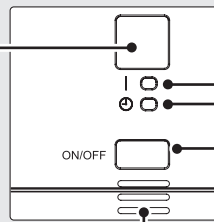

運轉指示燈 (綠色)

洗淨運轉

定時器指示燈 (黃色)

運轉 / 停止開關

- 按開關一次開始運轉。
- 再按一次停止運轉。
- 適合找不到遙控器時使用。

室外機

25/35機型

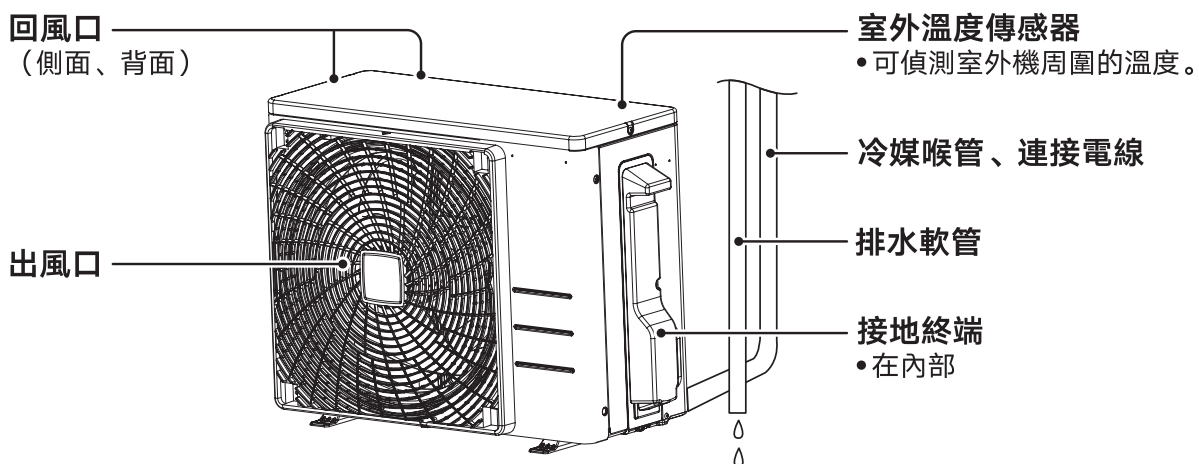

室外機外觀以實物為準。

室內機

50/60/71機型

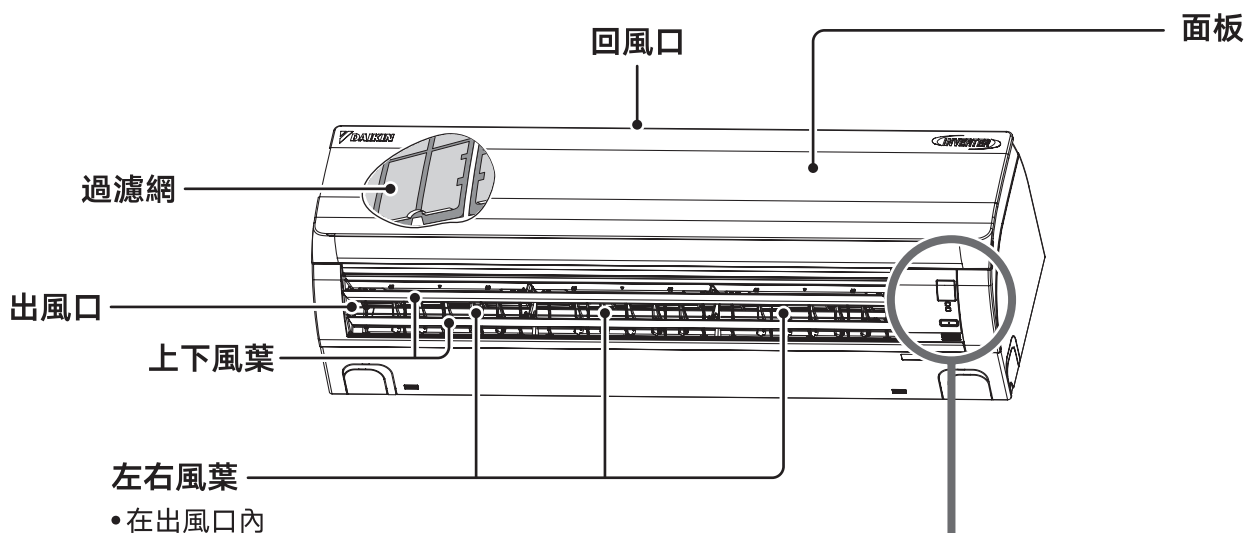

顯示

訊號接收器

- 接收遙控器發出的訊號。
- 一接收到訊號，會發出「嗶」聲，確認已收到訊號。
- 開始運轉：嗶嗶
- 改變設定：嗶
- 停止運轉：嗶—

室內溫度傳感器

- 偵測室內溫度

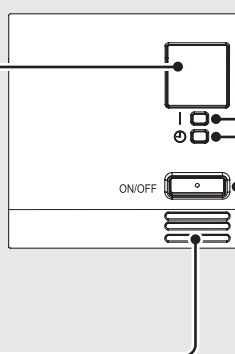

運轉指示燈 (綠色)

洗淨運轉

定時器指示燈 (黃色)

運轉 / 停止開關

- 按開關一次開始運轉。
- 再按一次停止運轉。
- 適合找不到遙控器時使用。

室外機

50/60/71機型

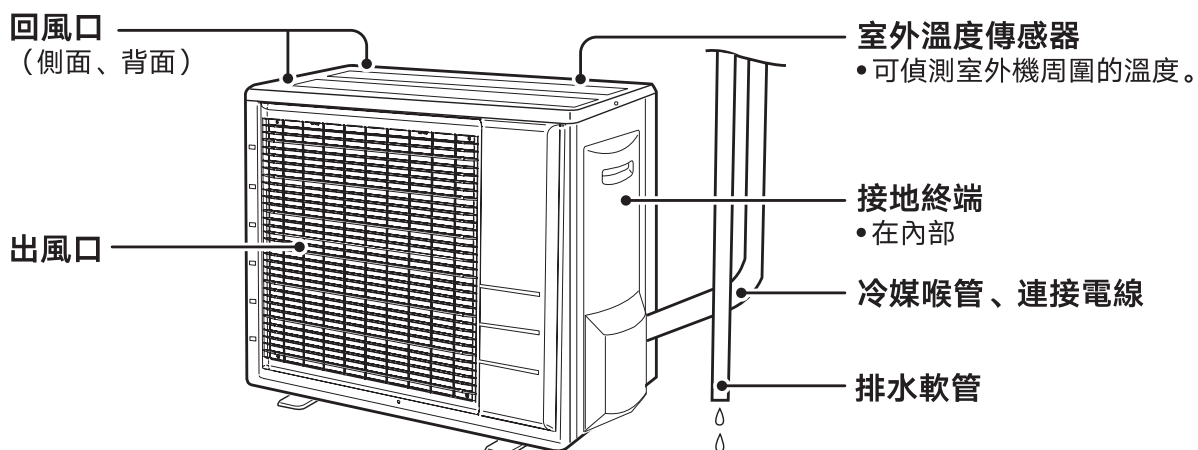

室外機外觀以實物為準。

遙控器

運轉

製冷

COOL 按鈕。

- 降低室內溫度。

除濕

DRY 按鈕。

- 降低室內濕度。

送風

FAN ONLY 按鈕。

- 讓室內空氣循環。

停止運轉：**OFF** 按鈕。

遙控器的顯示屏會關閉。

調整溫度、風量、風向

溫度

- 改變製冷模式下空調設定的溫度。
- 改變除濕模式的強度。

TEMP

風量

- 改變製冷或送風模式下的風量強度。

FAN

上下自動擺動

- 改變氣流的上下方向。

SWING

運轉顯示器

顯示器顯示空調機現時的設定
 (下圖顯示所有運轉模式，僅作說明用途，實際顯示可能視乎機型有所不同)。

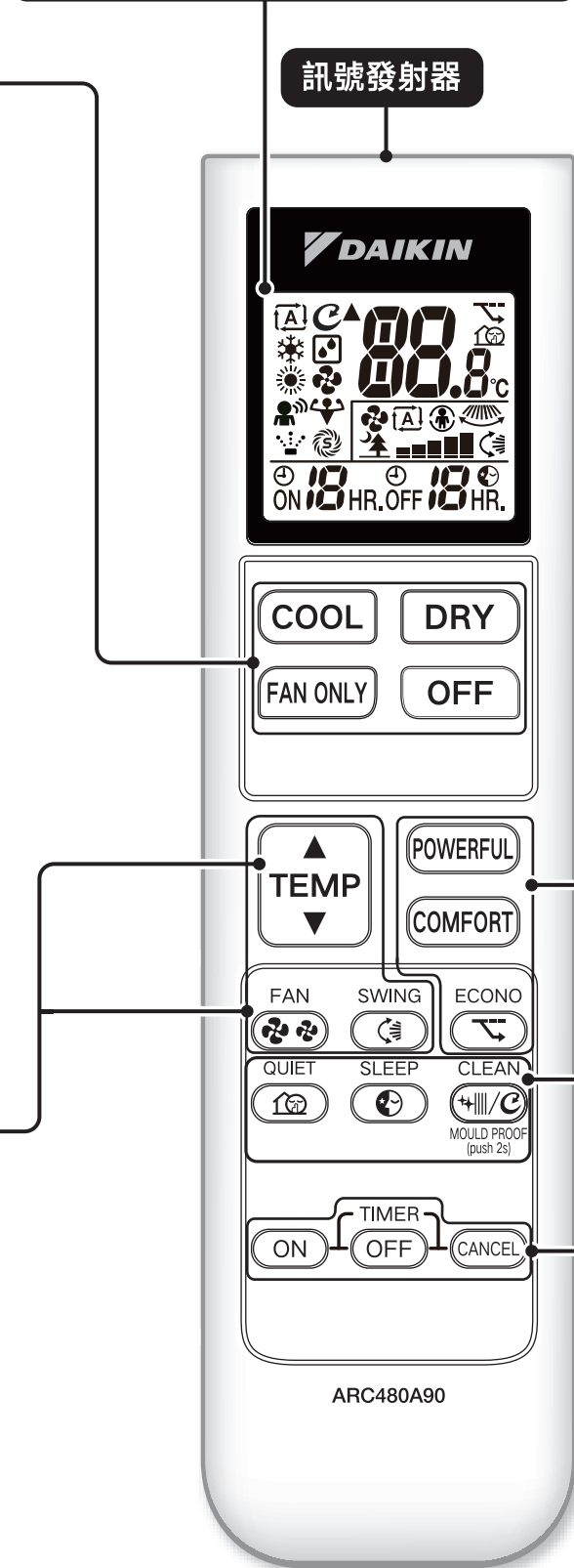

便利設定

強力運轉



- 在此模式下，空調機會立即以最大效能運轉。
- 若在運轉期間需要提升空調機效能，可以使用此功能。

舒適氣流運轉



- 根據製冷時不同的氣流分佈，空調機會控制氣流，讓吹出的風更加舒適。

節能模式



- 減少最大耗電量。
- 電器用電負荷過大時，可以啟動此功能，減少空調機帶來的負荷。

室外機靜音運轉



- 降低室外機音量，提供寧靜的室外環境。
- 夜間使用空調機時，可啟動此功能，不僅可以為自己製造寧靜的睡眠環境，也可以減少對鄰居的影響。

夜間睡眠運轉



- 睡前啟動此功能設定睡眠時間，有助於改善睡眠質素。

洗淨運轉 / 防霉運轉



- 洗淨運轉（短按）：清洗熱交換器，去除熱交換器上的灰塵（詳見74頁）。
- 防霉運轉（長按2秒）：使空調機內部乾燥，抑制霉菌和異味產生。

便利設定

定時開機



- 設定定時開機，讓空調機於指定時間啟動。

定時關機



- 設定定時關機，讓空調機於指定時間關閉。

取消



- 取消定時開機或關機的設定。
- 取消夜間睡眠運轉。

運轉前的準備

遙控器

放入電池

1 輕按蓋上的  標誌，取下電池蓋。

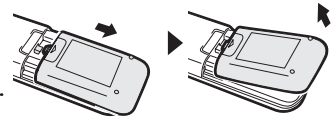

2 裝上兩顆AAA乾電池。

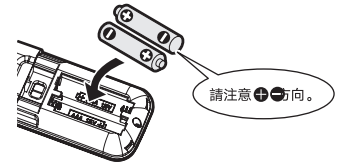

3 蓋上電池蓋。

遙控器的操作

- 使用遙控器時，要將訊號發射器對準室內機的訊號接收器。
如果窗簾等阻隔了遙控器與空調機間的訊號傳送，空調機可能會沒有回應。
- 不要弄濕或把遙控器掉入水中。
- 訊號傳輸的最遠距離為7m。

25/35機型

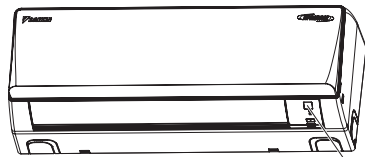

訊號接收器



50/60/71機型

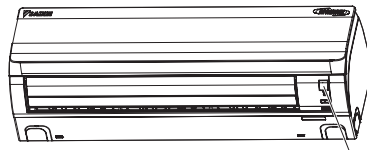

訊號接收器



關於電池

- 更換電池時，請同時更換兩顆電池，並使用同一種類的新電池。
- 長時間閒置時，請取出全部電池。
- 我們建議每年更換一次電池，但如果遙控器顯示屏顏色開始變淡或者不能正常接收訊號，請立即更換電池。
- 附件中的電池僅用於初始操作。電池的壽命或因空調機的生產日期而異。
- 必須在電池腐爛前更換，並安全地處理電池。

關於遙控器

- 如訊號發射器或訊號接收器上有灰塵，可能會影響訊號接收，請以柔軟的布擦拭乾淨。
- 在使用帶有電子式啟動器燈管（整流型燈管）的房間中，訊號接收或會比較困難。如遇到上述情況，請與銷售工程師聯絡。
- 如遙控器干擾其他設備運作，請移開該設備或與銷售工程師聯絡。
- 如果空調機上的訊號接收器與遙控器上的訊號發射器之間有障礙物，可能會影響訊號傳輸，空調沒有回應。

接通電源

- 一旦接通電源，所有風葉會順序打開，然後關上（這不是故障）。

正確的使用方法

- 請不要將房間溫度調得過低 / 過高。
請將溫度設定在適當的範圍內。
- 請裝上百葉窗或窗簾。
擋住陽光和室外的空氣，提升製冷效能。
- 如果過濾網的網眼堵塞，會降低製冷效能，浪費電力。建議每兩週清洗過濾網一次。

適當的溫度設定範圍

製冷時 26°C ~ 28°C

請事先了解

- 空調機不運轉時也要消耗2.0W功率。
- 當空調機長時間閒置時，請關閉電源。
- 請在以下情況下使用空調機。

運轉模式	運轉條件	如在不符合運轉條件的情況下使用空調機
製冷	室外溫度： 10 ~ 46°C 室內溫度： 18 ~ 32°C 室內濕度： 80%以下	<ul style="list-style-type: none">● 保護裝置將被啟動，機組可能停止運轉。● 空氣間的水份可能在室內機凝結成水，導致滴水。
除濕	室外溫度： 10 ~ 46°C 室內溫度： 18 ~ 32°C 室內濕度： 80%以下	<ul style="list-style-type: none">● 保護裝置將被啟動，機組可能停止運轉。● 空氣間的水份可能在室內機凝結成水，導致滴水。
洗淨運轉	室外溫度： 3°C以上	<ul style="list-style-type: none">● 空調機會發出蜂鳴聲，但洗淨運轉模式不會啟動。

- 除了不符合上述運轉條件外，保護裝置亦可能因其他原因而啟動，導致機組不能運轉。
- 當室外溫度低於-15°C，空調機會停止運轉。

智能控制

■ 下載Daikin Advance的方法

- Android裝置使用者請在Google Play搜尋「Daikin Advance」。
- iOS裝置使用者請在App Store搜尋「Daikin Advance」。

說明：

- 請檢查裝置操作系統版本，此應用程式支援Android 6.0及iOS 12.0或以上的版本（有關操作系統的要求可能會隨著應用程式的版本而有所改變，請在下載應用程式時參考相關需求）。
- 隨著應用程式及操作系統的更新，應用程式的界面可能會有所不同，實際界面以應用程式為準。
- 在應用程式更改的設定不會顯示在無線遙控器上，所以遙控器上的顯示與實際運轉情況可能不同。
- 遙距控制空調機時，請確保行動裝置和空調機均連接至網絡。
- 不要在微波爐或其他2.4GHz無線頻率設備附近使用本空調機，否則可能接收不到無線訊號。

無線連接設定

■ 設定前的準備

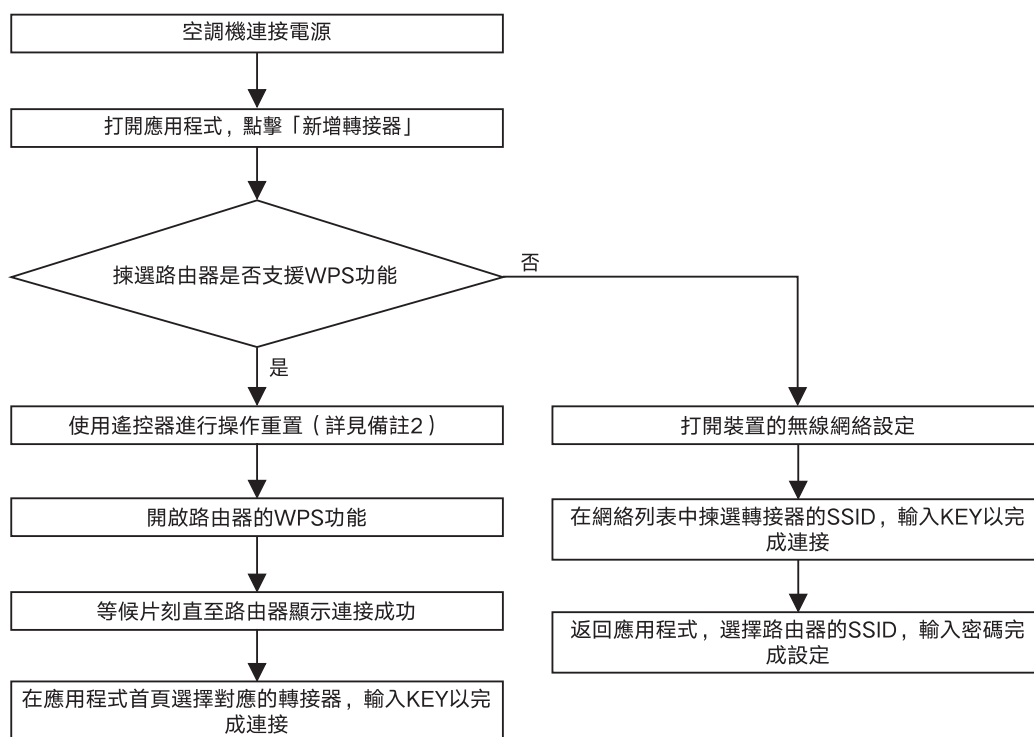

- 路由器需連接網絡和接通電源，以確保能正常運作。

■ 空調機設定



備註1：請根據應用程式中的指示逐步完成設定。

備註2：重置Wi-Fi前請先確保空調機處於停機狀態（關機並不等於停機，關掉機組後，部份模式可能仍在運轉狀態，請耐心等待）。
如使用遙控器重置Wi-Fi，當遙控器關閉時，長按“”5秒以上，直至遙控器的顯示屏出現“SP”（如右圖所示）。

按“”直至顯示屏出現“2”，再按“”確認。

備註3：若設定過程出現網絡異常的現象，請先檢查路由器的網絡是否正常運作。

若正常，請關閉並重新接通電源以重啟空調機，或重置Wi-Fi以恢復網絡。

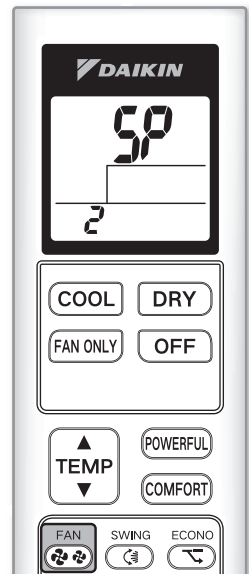

除濕 / 製冷 / 送風運轉

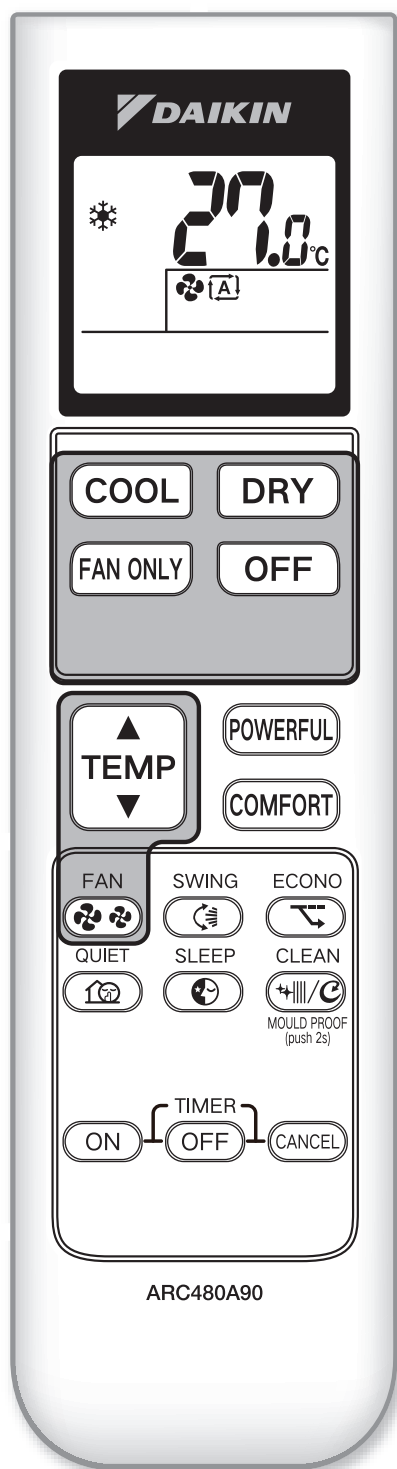

空調機有製冷、除濕、送風三種運轉模式，用家可根據需求選擇模式。

開始運轉

根據需求按“COOL”，“DRY”或“FAN ONLY”開始運轉。

※圖像以25/35機型為例。

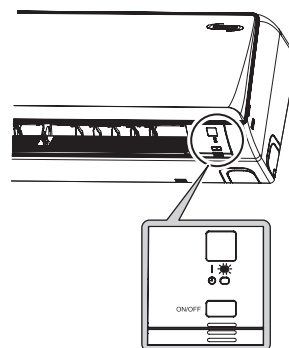

- 運轉指示燈亮起（綠色）。

停止運轉

按“OFF”。

調節溫度

按“TEMP”。

送風運轉	不能調節溫度。
製冷運轉	想調高溫度時按“▲”，想調低溫度時按“▼”。
	設定特定溫度。 
除濕運轉	按“▲”調高溫度，按“▼”調低溫度控制除濕能力（調節範圍±2°C。）。

調節風量

按“”。

除濕運轉	不能調節風量。
製冷、送風運轉	從「最低」到「最高」，共有五種風量可供設定，另外還有「自動」、「靜音」。 

● 室內機靜音運轉

當風量設定為“”時，室內機的音量會降低。

當風量設定為低時，空調機的效能會有所下降。

關於製冷運轉

- 由於本空調機通過將室內熱量釋放至室外來降低室溫，所以當室外溫度過高時，製冷能力或會隨之下降。
- 當達到設定溫度後，空調機會把溫度、濕度控制在舒適的狀態。

關於除濕運轉

- 電腦晶片控制除濕功能，除濕的同時控制房間溫度在特定水平。
- 除濕後的冷空氣混合室內空氣，調整氣流溫度，去除濕氣。
- 空調機會自動控制溫度和風量，不能手動調節。
- 當室外溫度比室內溫度低時，除濕效果會下降。

關於風量設定

- 風量較小時，製冷效能亦會較小。

風向調節

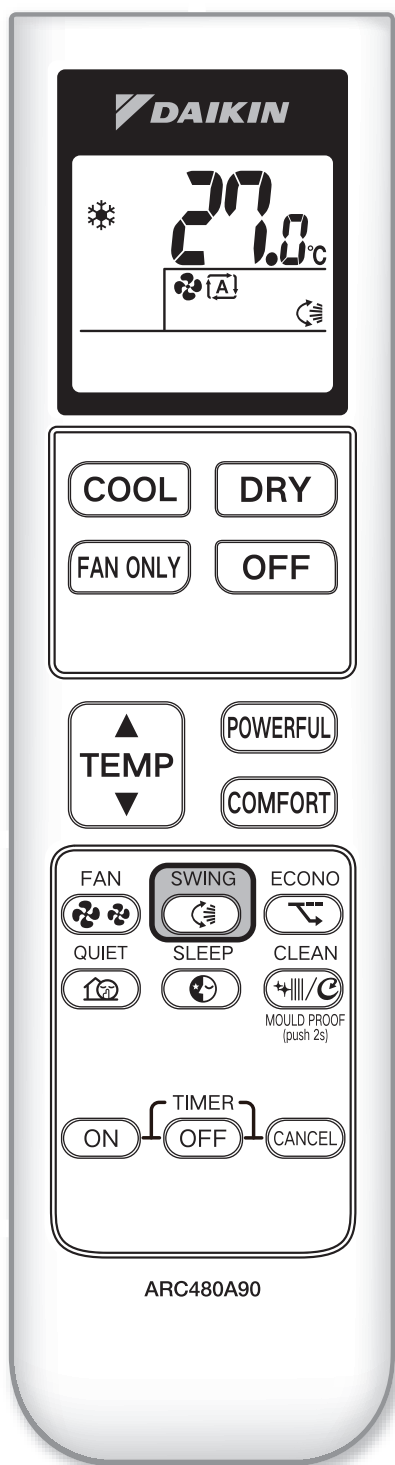

能準確地調節風向，締造舒適的氣流。

調節上下風葉

按“”。

- 顯示屏出現“”，上下風葉開始上下擺動。

當上下風葉達到理想位置時，再次按“”。

- 顯示消失。
- 上下風葉停止擺動。

調節左右風葉

- 握著把手向左右移動（風葉左右兩側各有一個把手）。
- 若要調節風向，必須使用遙控器調節上下風葉，左右風葉則須在機組停止運轉時調節。

關於風向調節

- 當空調機安裝在房間的角落時，不可將左右風葉對準牆壁，因為牆壁會阻擋空調機吹出的風，降低製冷效果。

關於上下風葉的角度

- 按下 “” 後，上下風葉的擺動幅度取決於當下的運轉模式（見下圖）。

25/35機型

除濕或製冷運轉

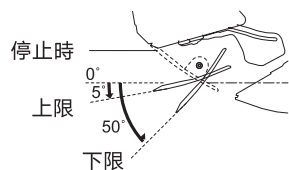

送風運轉

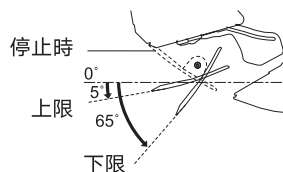

50/60/71機型

除濕或製冷運轉

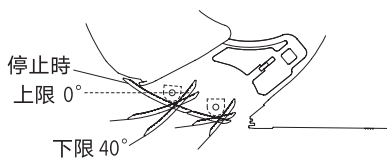

送風運轉

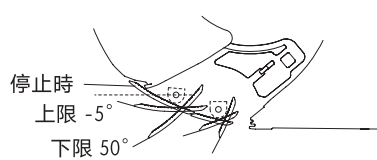

注意

- 空調機運轉期間，如強行用手調節上下風葉，可能會損壞裝置；由於出風口內側的風扇正高速運轉，如在機組運行期間用手調節左右風葉，可能會釀成意外。

舒適氣流運轉

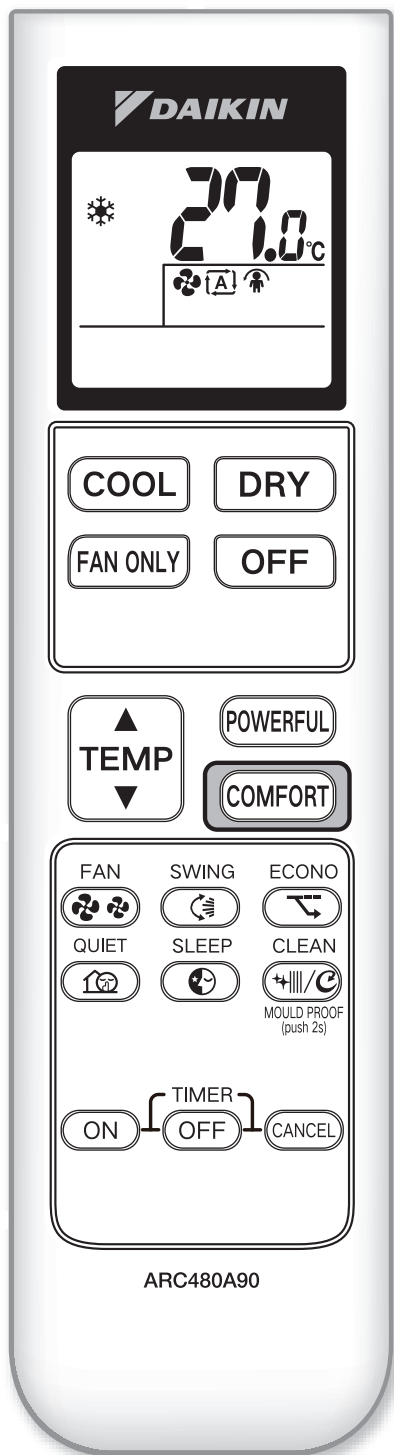

通過自動調節風向，讓氣流平均分佈房間每個角落。製冷時，氣流不會直接吹向用家，無感送風。

啟動舒適氣流運轉

按“COMFORT”。

- 製冷、除濕、送風運轉時，顯示屏會出現“”。

取消舒適氣流運轉

再次按“COMFORT”。

- 顯示屏上的“”消失。
- 上下風葉恢復到啟動舒適氣流運轉前的送風角度。

關於舒適氣流運轉

- < 製冷、除濕、送風運轉 > 風葉向上擺動，停在上方。
風葉向上時：

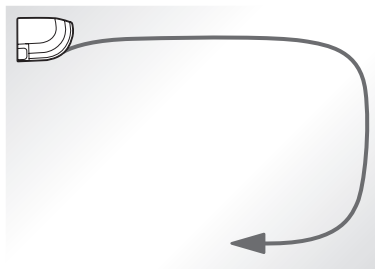

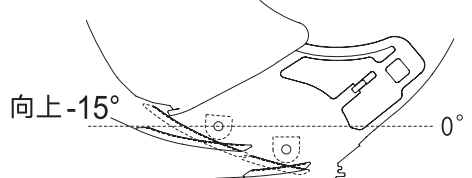
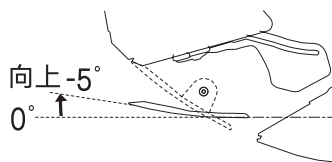

上下風葉角度：
25/35機型

50/60/71機型



上下風葉向上吹風，結合特殊設計，避免冷風直接吹向用家。

- 康達效應氣流指利用康達效應（Coanda effect）產生的氣流。
- 舒適氣流運轉期間可自由選擇風量，建議使用自動風量。
- 當風量設定為低時，本功能的效能會減弱。
- 如房間頂部有障礙物，會影響舒適氣流運轉的效果。
- 舒適氣流運轉期間，電腦晶片會自動控制上下風葉擺動，這不是異常。
- 按下“POWERFUL”，“”的時候，舒適氣流運轉會被解除，顯示屏上的“”會消失。

洗淨運轉

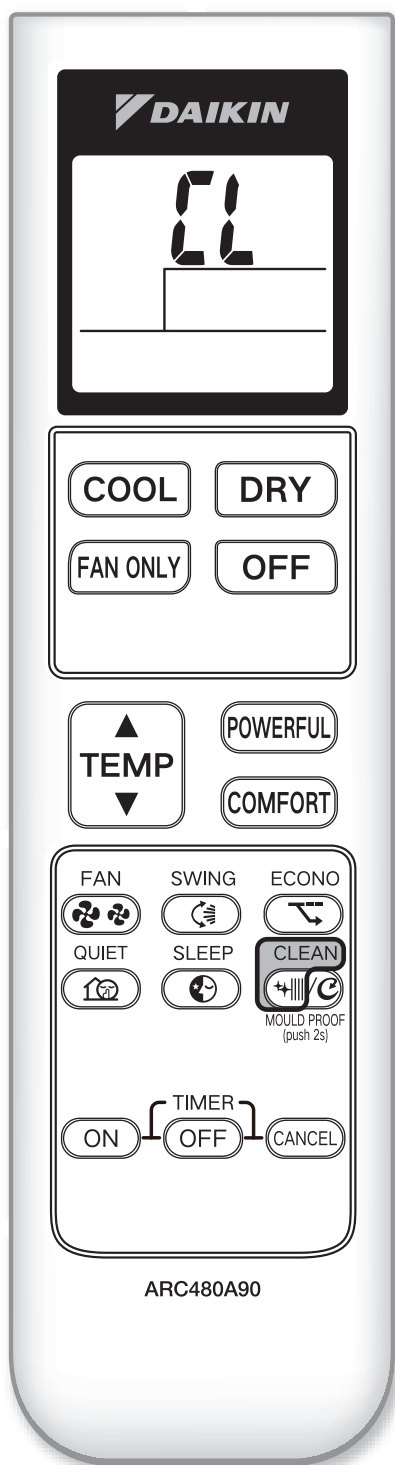

※圖像以25/35機型為例。

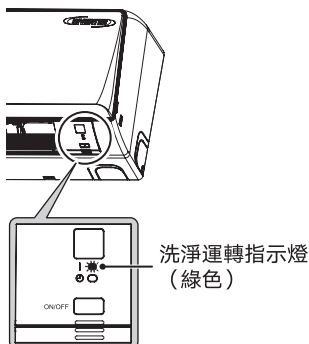

冷氣機用製冷凝水將污垢從熱交換器排走，保持熱交換器清潔同時去除異味，再將熱交換器吹乾。

啟動洗淨運轉

在停機狀態按“”。





- 顯示屏出現“”，並閃爍兩次。
- 洗淨運轉啟動。
- 洗淨運轉指示燈亮起。

停止洗淨運轉

再次按“”。

- 顯示屏出現“”，並閃爍兩次。
- 停止洗淨運轉。
- 洗淨運轉指示燈熄滅。

關於洗淨運轉



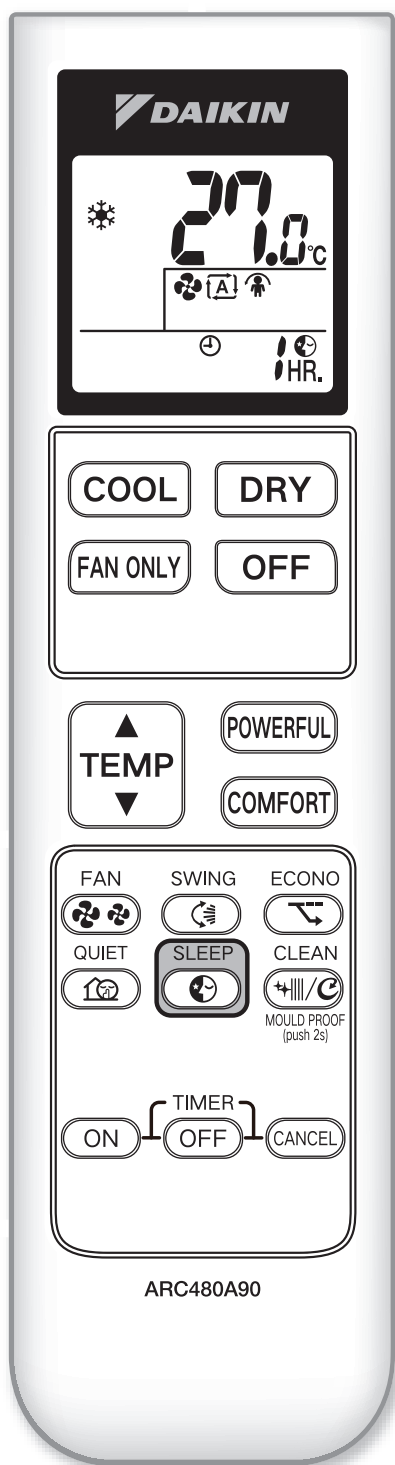

- 為保護空調，當室外環境低於3°C時，洗淨運轉將無法啟動，這不是故障。
- 洗淨運轉包括冷凝水清洗以及吹乾，整個過程大概需時2小時。
- 洗淨運轉期間可能會產生輕微的聲音，或有冷風吹出，這不是故障，建議在沒有人的房間中使用此功能。
- 最適合冷凝水清洗的環境：室內溫度15°C - 27°C；室內濕度30% - 60%。請在上述環境啟動洗淨運轉模式，若不符合以上條件，可能達不到預期的清潔效果。
- 洗淨運轉啟動期間，按下“”、“”、“”的時候，會停止洗淨運轉，然後按照遙控器的設定繼續運轉。洗淨運轉期間，“”按鈕會無效。支援Wi-Fi操作的機型在洗淨運轉期間，應用程式亦會無效。
- 洗淨運轉啟動期間，按“”（防霉運轉）會停止洗淨運轉，但不會進入防霉運轉。
- 洗淨運轉啟動期間，水平風葉的位置會被固定，不能用遙控器調校。

夜間睡眠運轉





配合睡眠時體溫的下降，此功能在夜間會逐漸降低溫度，並在早上提高溫度（V型溫度控制），以營造良好的睡眠環境。

設定夜間睡眠運轉

- 在製冷模式下按“”。
- 顯示屏上顯示“  1HR.”。
- 繼續按“”設定起床時間（1-12小時），每按一次，時間會延長1小時。



取消夜間睡眠運轉

- 按“”。
- 顯示屏上的“  1HR.”會消失。

關於夜間睡眠運轉

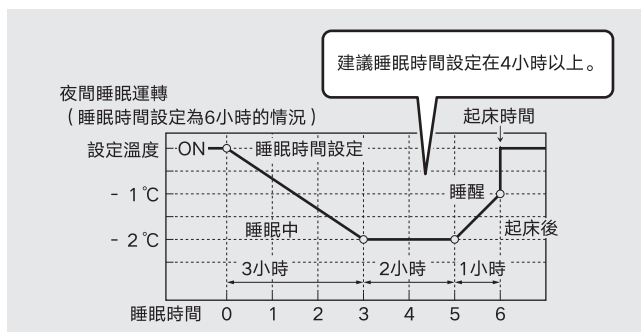
- 只要設定過一次夜間睡眠運轉，設定的時間就會被儲存，方便下次使用（更換電池後需重新設定）。
- 設定夜間睡眠運轉後，設定溫度會在大約3小時內下降2°C，起床前（約1小時）設定溫度會回升1°C（V型溫度控制）。結束夜間睡眠運轉後，溫度會回復至設定溫度。



- 本功能只能在製冷模式下使用。
- 夜間睡眠運轉與定時器運轉不能同時使用，空調機會優先執行先揀選的模式。
- 夜間睡眠運轉啟動期間，上下風向固定，風量為自動。
- 夜間睡眠運轉啟動期間，室內機的指示燈會熄滅，這不是故障。
- 夜間睡眠運轉啟動期間，不能使用“”，“”，“”。

強力運轉

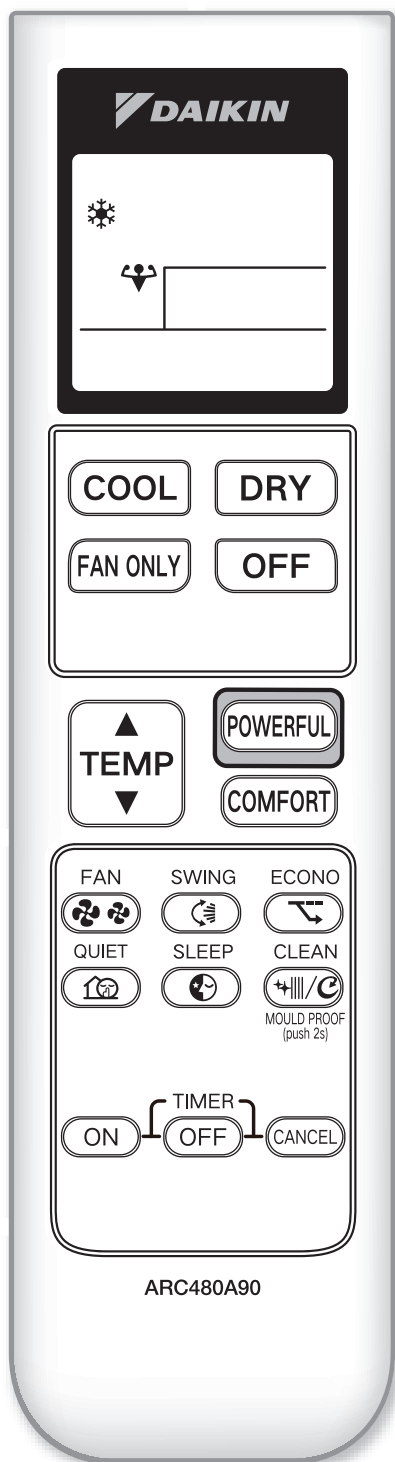

在製冷模式中，只要啟動強力運轉，可立即提高當前模式的效能。在除濕、送風啟動期間不能使用此功能。

啟動強力運轉

按“POWERFUL”。





- 顯示屏上顯示“”。

取消強力運轉

再次按“POWERFUL”。

- 顯示屏上的“”消失。

關於強力運轉

- 強力運轉啟動後約20分鐘，空調機會自動回復到啟動強力運轉前的設定狀態，顯示屏上的“”會消失。
- 製冷模式期間：
製冷效能提升。
溫度和風量不能改變。
- 強力運轉僅能在空調機運轉期間使用。
- 如按下“COMFORT”、“”、“”、“”，強力運轉會被解除，顯示屏上的“”會消失。

節能模式

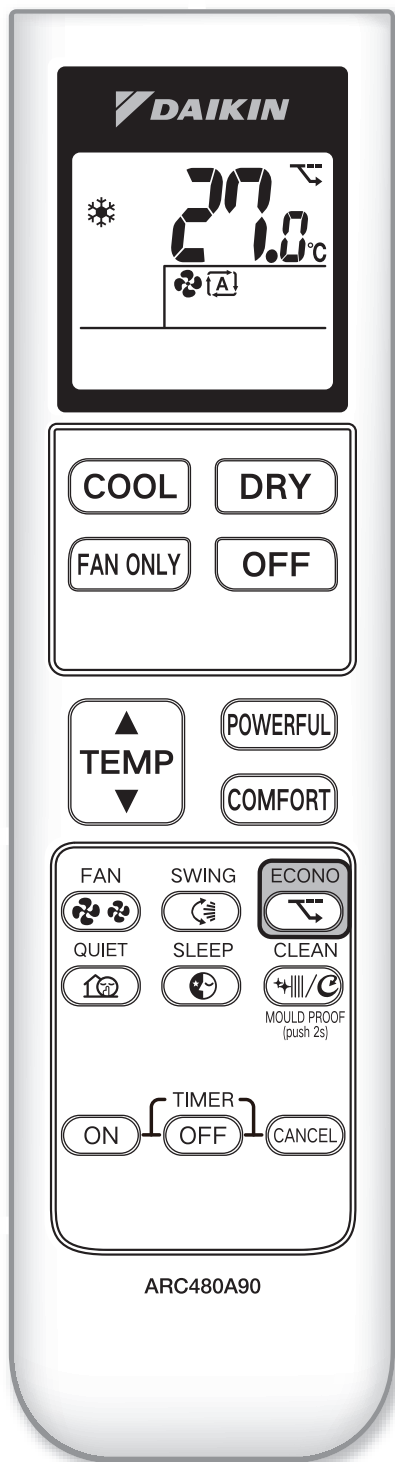

節能模式可以降低最大耗電量。

啟動節能模式

按“”。



- 顯示屏上顯示“”。

取消節能模式

再次按“”。

- 顯示屏上的“”消失。

關於節能模式

- 節能模式僅可在製冷、除濕運轉期間設定和使用，運轉停止後，設定會解除，顯示屏上的“”會消失（送風模式下不能使用）。
- 如按下“POWERFUL”，節能模式會被解除，顯示屏上的“”會消失（除濕模式下除外）。
- 此模式下，製冷或除濕效能都會減弱。
- 當空調機耗電量偏低時，即使啟動此功能，有時也不能減少耗電量。

室外機靜音運轉

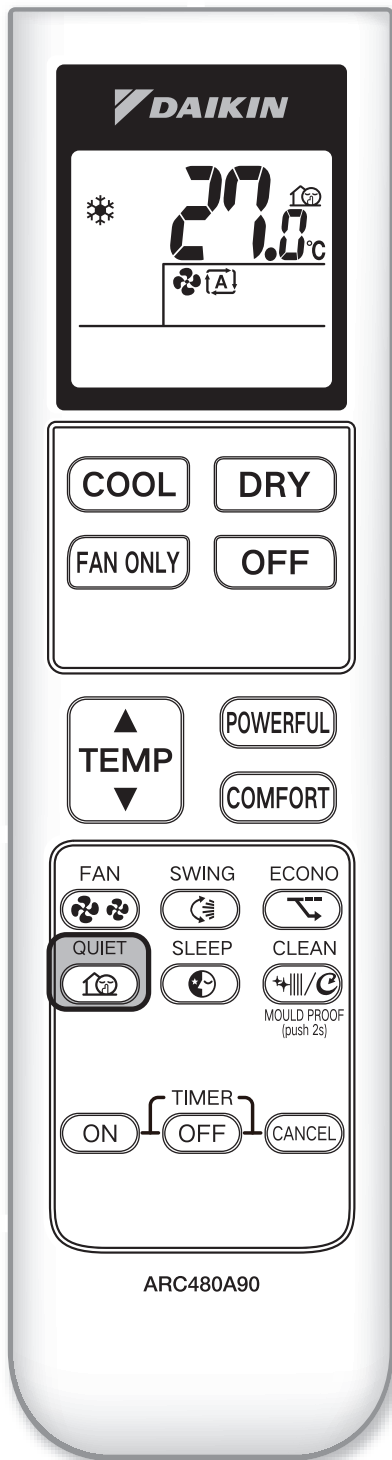

室外機靜音運轉啟動期間，室外機壓縮機的頻率和風扇轉速會有改變，從而降低音量。此功能可在夜間保持環境寧靜。

啟動室外機靜音運轉

按“”。



- 顯示屏上顯示“”。

取消室外機靜音運轉

再次按“”。

- 顯示屏上的“”消失。

關於室外機靜音運轉

- 室外機靜音運轉僅可在製冷運轉期間設定和使用（送風和除濕模式下不能使用）。
- 如按下“”，室外機靜音運轉會被解除，顯示屏上“”會消失。
- 此模式下，製冷效能都會減弱。

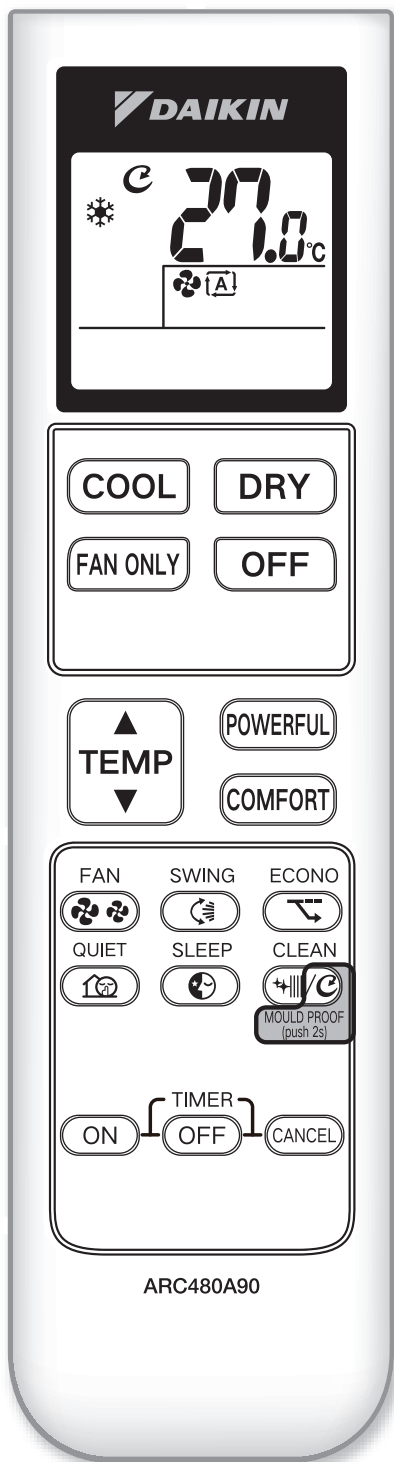

防霉運轉



通過一段時間的送風運轉使空調機內部乾燥，抑制因空調機內部潮濕而產生的霉菌和異味。用家可設定自動防霉運轉，亦可以按實際需求啟動防霉運轉。

設定自動防霉運轉

出廠設定為「關」

- 運轉期間長按“” 2秒。
- 顯示屏上顯示“”。
- 在製冷、除濕模式運行一段時間後關機，空調機會自動啟動防霉運轉。



取消自動防霉運轉

- 運轉期間長按“” 2秒。
- 顯示屏上的“” 消失。

啟動手動防霉運轉

- 關機狀態下長按“” 2秒。
- 顯示屏上的“” 閃爍兩次。
- 啟動防霉運轉。

手動停止防霉運轉

- 防霉運轉期間長按“” 2秒。
- 顯示屏上的“” 閃爍兩次。
- 停止防霉運轉（不會影響自動防霉運轉的設定）。

關於防霉運轉

- 在製冷、除濕運轉停止後，自動防霉運轉將運行約1.5小時，耗電量為0.014kWh。
- 自動防霉運轉期間，風扇會持續運轉，這不是故障。
- 自動防霉運轉不能去除附著的灰塵和霉菌。
- 如有設定定時關機，空調機不會啟動自動防霉運轉。

定時器運轉

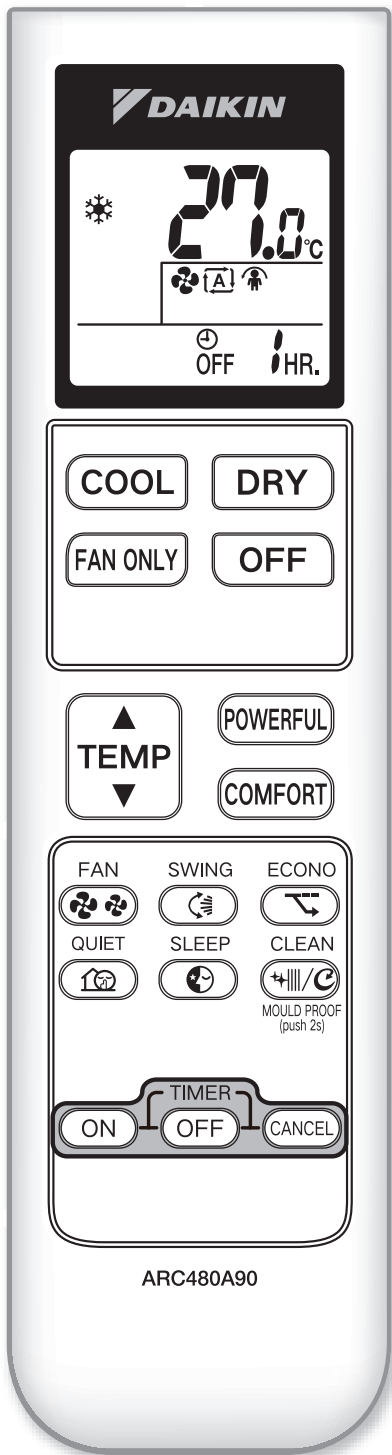

設定開機及關機時間掣，讓空調機按時間表自動開關。

啟動自動定時關機

按“OFF”。

顯示屏上顯示“OFF 1HR.”

定時器指示燈亮起。

- 繼續按“OFF”設定關機時間。
- 時間設定範圍為1-12小時，每按一次“OFF”，關機時間會延長1小時。

※圖像以25/35機型為例。

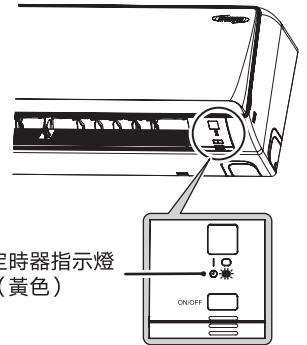

取消定時關機運轉

按“CANCEL”。

- 顯示屏上的“OFF 1HR.”消失。
- 定時器指示燈熄滅。

定時器運轉

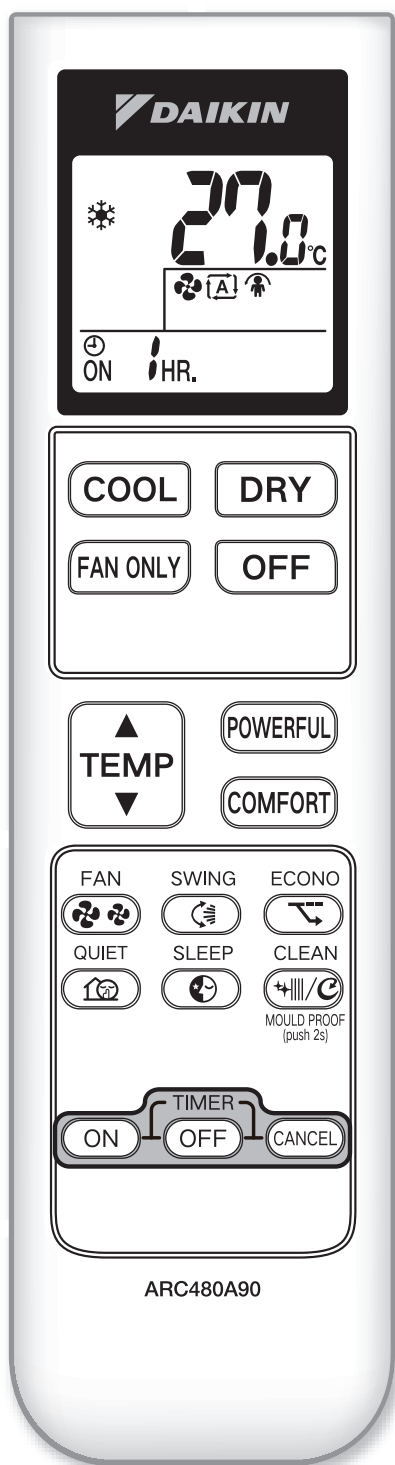

啟動自動定時開機

按“ON”。

顯示屏上顯示“ON 1 HR.”

定時器指示燈亮起。

繼續按“ON”設定關機時間。

- 時間設定範圍為1-12小時，每按一次“ON”，關機時間會延長1小時。

※圖像以25/35機型為例。

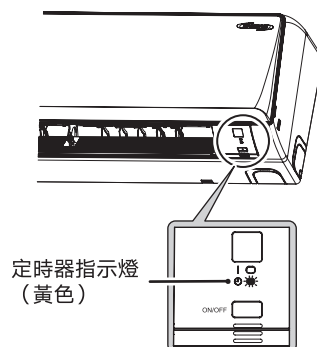

定時器指示燈
(黃色)

取消定時開機運轉

按“CANCEL”。

- 顯示屏上的“ON 1 HR.”消失。
- 定時器指示燈熄滅。

同時啟動定時開機和定時關機

同時啟動定時開機和定時關機時，請參考以下例子。

例

3小時後關機；
8小時後開機。



ON 8 HR. OFF 3 HR.

注意

■如遇到以下情況，請重新設定定時器。

- 關閉電源後。
 - 停電後。
 - 更換遙控器的電池後。
-
- 定時器運轉與夜間睡眠運轉不能同時使用，空調機會優先執行先揀選的模式。
 - 只要設定過一次定時器運轉，設定的時間就會被儲存，方便下次使用（更換電池後需重新設定）。

保養與清潔

⚠ 注意

- 進行空調機保養前，必須停止運轉及關閉電源。

空調設備

室內機、室外機和遙控器

用乾的軟布輕拭。

面板

※圖像以25/35機型為例。

1 打開面板。

- 用手指扣著室內機兩側的凹陷部份，將面板打開。

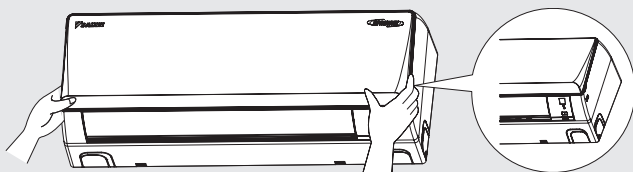

2 取下面板。

- 稍微向右滑動面板，同時輕輕向上推，再將面板往外抽出，拆下左下旋轉軸。

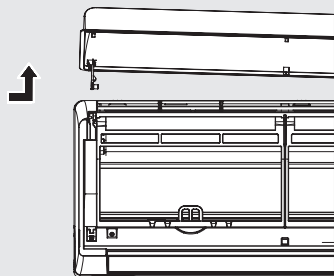

3 清潔面板。

- 用濕的軟布輕拭（只能用中性清潔劑清洗）。
- 清潔面板後，用布擦去水份，在放在陰涼處晾乾。

4 安裝面板。

- 將面板的鉤對準凹槽，然後壓到底部。
- 慢慢關上面板，按壓面板上的3個位置（左右兩側和中間位置）。

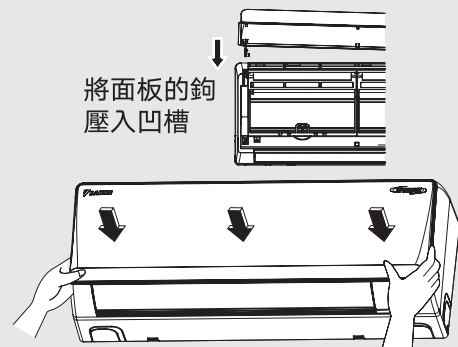

⚠ 注意

- 不要觸摸室內機的金屬部份，以免受傷。
- 不得使用以下物品（可能會造成變形、刮痕）：
40°C或以上的熱水；
揮發性物質如揮發性油脂、汽油、稀釋劑等；
拋光粉；
硬物如刷子。
- 清潔面板時，請使用穩固的梯子，慎防跌倒。
- 如要更換面板，請聯絡銷售工程師。非專業人士拆除面板可能會導致面板無法正常運作或損毀。

保養與清潔

當過濾網有污垢時

⚠ 注意

- 打開或關閉面板時，請使用穩固的梯子，慎防跌倒。

過濾部份

※圖像以25/35機型為例。

1 打開面板。

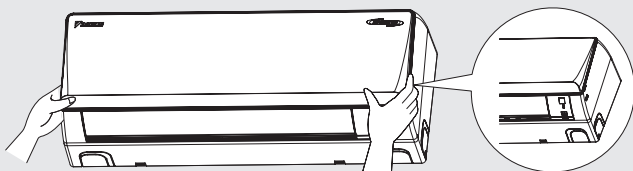

2 抽出過濾網。

- 把過濾網的左右旋鈕稍微向前提起，然後向下抽出。

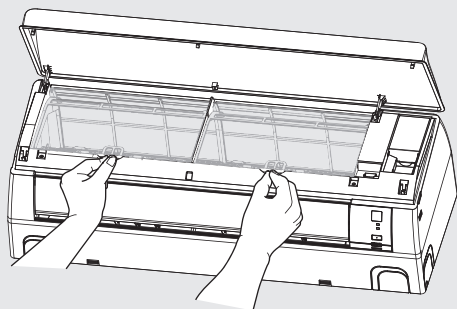

3 清潔或更換過濾網。

- 參閱下面。

4 重新安裝過濾網，關上面板。

- 將過濾網的搭扣按入前格柵的槽中。慢慢關上面板，按壓面板上的3個位置（左右兩側和中間位置）。

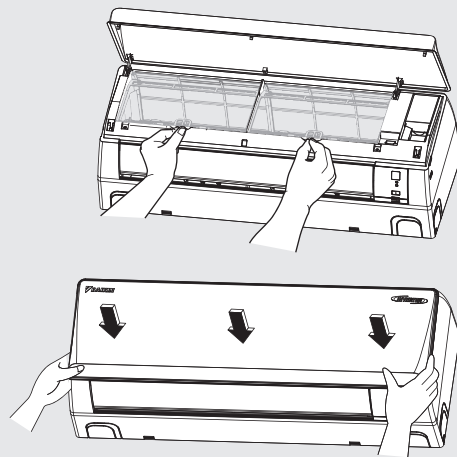

過濾網

用水清洗過濾網或用吸塵機清潔。

- 如果灰塵不易清除，請用稀釋的中性清潔液清洗過濾網，然後放在陰涼處晾乾。
- 建議每2星期清潔過濾網一次。

-保養-

- 1 用吸塵機吸走灰塵，用水輕輕沖洗。
- 2 如果過濾網很骯髒，可將過濾網浸泡在加入中性清潔劑的水中10-15分鐘。
- 3 清洗乾淨後，把過濾網甩乾並放在陰涼處晾乾。

保養與清潔

⚠ 注意

- 過濾網積上灰塵時，空調機仍可運作，但可能導致：
 - (1) 吹出的風不乾淨。
 - (2) 製冷效能會減弱。
 - (3) 運行時發出異味。
 - (4) 過濾網變色。
- 購買過濾網時，請諮詢銷售工程師。
- 過濾網是不可燃的物件，請以適當的方法棄置。

建議定期檢查空調機機組

- 檢查室外機的底座、安裝架及其他固定零件有沒有腐爛或銹蝕的情況。
- 檢查室內機或室外機的回風口、出風口有沒有堵塞。
- 進行製冷、除濕、洗淨運轉時，檢查排水軟管是否有水排出。
 - 如果沒有水排出，室內機可能會出現漏水情況。如遇到此情況，應停止運轉，並與銷售工程師聯絡。

長期間置時

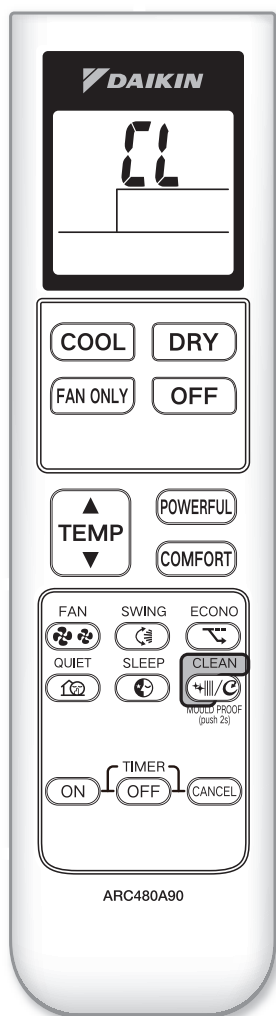

1 晴天的日子啟動「洗淨運轉」約2小時，清洗室內機熱交換器的表面。

- 參考74頁。

2 運轉結束後，關閉室內機電源。

3 清潔過濾網後，將過濾網裝回原位。

- 參考83頁。

4 取出遙控器的電池。

疑難排解

不是故障 以下情況不是故障，你可以繼續使用空調機。

情況	說明
<p>沒有立即運轉。</p> <ul style="list-style-type: none"> ● 空調機停止運轉後，立即再啟動機組。 ● 改變運轉模式後。 	<ul style="list-style-type: none"> ● 為了保護空調機，停止運轉後，請等待3分鐘才再次啟動機組。
<p>室外機出水或產生水蒸氣。</p>	<p>■ 製冷、除濕、洗淨運轉時</p> <ul style="list-style-type: none"> ● 空氣中的水份凝結在室外機的冷媒喉管並滴下。
<p>室內機冒出水汽。</p>	<ul style="list-style-type: none"> ● 製冷運轉期間房間的空氣變冷而產生的水汽。 ● 洗淨運轉期間房間的空氣變冷而產生的水汽。
<p>空調機產生異味。</p>	<ul style="list-style-type: none"> ● 室內機會吸入房間、家具、香煙等氣味，然後排放到空氣中（建議請技術人員來清洗室內機）。
<p>停止運轉後，室外機的風扇仍在轉動。</p>	<p>■ 停止運轉後</p> <ul style="list-style-type: none"> ● 為了保護空調系統，室外機風扇大約會轉動60秒。 <p>■ 關機狀態時</p> <ul style="list-style-type: none"> ● 當室外溫度高，為了保護空調系統，室外機風扇會轉動一段時間。 
<p>突然停止運轉（運轉燈亮起）。</p>	<ul style="list-style-type: none"> ● 為了保護空調系統，當出現電壓急變時，系統可能會停止運作，然後在約3分鐘後自動恢復運作。
<p>室內機無法接收遙控器的訊號；遙控器的靈敏度低；遙控器顯示屏的顏色變淺、沒有顯示或不能正常控制。</p>	<ul style="list-style-type: none"> ● 遙控器運作異常可能由電池耗盡引致，請更換全部電池（參考65頁）。 ※請於更換新電池後按下重設按鈕（如適用）。

不
是
故
障

疑難排解

再次檢查

預約維修前，請再次檢查以下事項。

情況	請檢查
<p>機組不運轉 (運轉燈熄滅)。</p> 	<ul style="list-style-type: none">● 電源是否關閉或保險絲是否斷了？● 是否停電？● 遙控器是否裝有電池？● 定時設定是否正確？
<p>製冷效果不佳。</p>	<p>再 次 檢 查</p> <ul style="list-style-type: none">● 過濾網是否骯髒？● 室內機與室外機的回風口、出風口是否堵塞？● 遙控器的設定溫度是否適當？● 門窗是否開著？● 風量調節、風向調節是否適當？
<p>運轉期間停止運轉 (運轉燈閃爍)。</p>	<ul style="list-style-type: none">● 過濾網是否骯髒？● 室內機與室外機的回風口、出風口是否堵塞？ <p>首先關閉電源，然後清潔過濾網或清除障礙物。接通電源後，用遙控器重啟空調機。如果運轉燈仍在閃爍，請聯絡銷售工程師。</p>
<p>運轉期間出現異常。</p>	<ul style="list-style-type: none">● 如出現電路不穩或無線電波等，可能會影響系統正常運轉。請關閉電源，然後再次打開，再用遙控器重啟空調機。
<p>停止運轉後，室內機仍在運作。</p>	<ul style="list-style-type: none">● 是否正在啟動防霉運轉？ <p>防霉運轉啟動時，運轉燈會熄滅，室內機風扇會繼續運轉。</p>

故障診斷

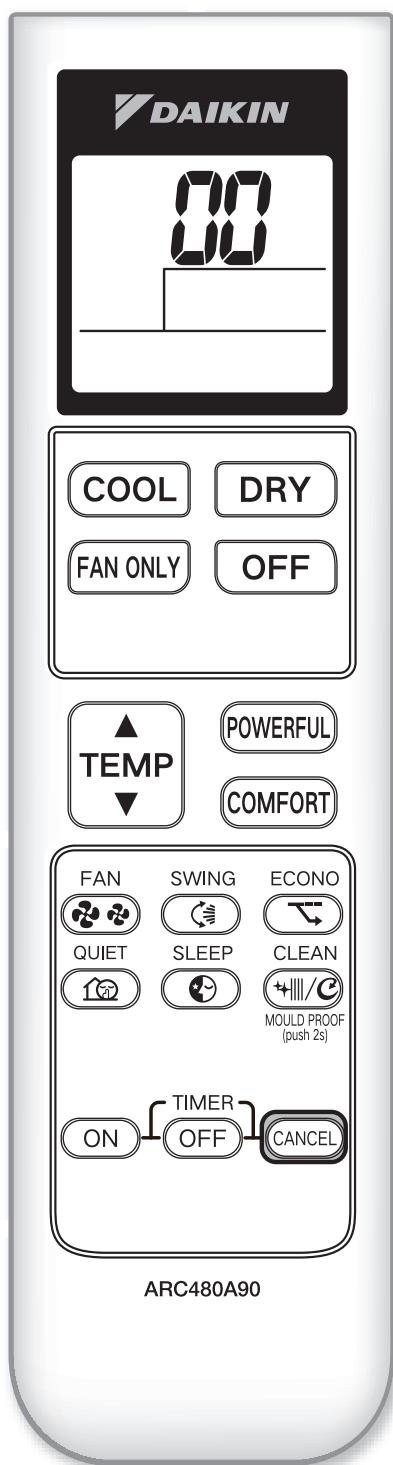

故障診斷

通過遙控器進行故障診斷

■ 遙控器ARC480A90（白色）的溫度顯示位置可以顯示相應代碼。

1 長按“CANCEL”5秒後，溫度顯示位置會出現閃爍的“00”。

2 按“CANCEL”多次，直到聽到一聲「嗶」。

- 顯示的代碼會根據下表改變，同時發出持續的「嗶」聲。

	代碼	說明
系統	00	正常
	UA	室內機-室外機組合故障
	U0	冷媒不足
	U2	電壓下降或主電路過電壓
	U4	訊號傳輸故障（室內機和室外機之間）
室內機	A1	室內機電子板故障
	A5	高壓控制或保護裝置凍結
	A6	風扇馬達故障
	C4	熱交換器溫度熱敏電阻故障
	C9	室溫熱敏電阻故障
室外機	E1	電路板故障
	E5	過載保護啟動
	E6	壓縮機啟動故障
	E7	風扇馬達故障
	F3	排出管溫度過高
	F6	高壓控制（製冷）
	H0	傳感器故障
	H6	錯位傳感器故障
	H8	電流傳感器故障
	H9	外氣溫度熱敏電阻故障
	J3	排出管熱敏電阻故障
	J6	熱交換器溫度熱敏電阻故障
	L3	電氣部件燒毀
	L4	變頻電路散熱器溫度過高
L5	輸出電流過載	
P4	變頻電路散熱器熱敏傳感器故障	

說明

- 「嗶」聲和兩次連續的「嗶」聲代表不同的代碼。
- 長按「定時器取消」按鈕5秒可關掉代碼顯示。如果1分鐘內不按任何按鈕，代碼顯示會自動關掉。

請立即與銷售工程師聯絡



警告

- 出現異常情況（如有燒焦味）時，要立即停止運轉，關閉電源。
若在異常情況下繼續運轉，可能會造成故障、觸電、火災等。
請與銷售工程師聯絡。
- 不要擅自維修或改造空調機。
可能會觸電或釀成火災。
請與銷售工程師聯絡。

出現以下情況時，請立即與銷售工程師聯絡。

- 電源線異常發熱或有損壞。
- 運轉期間產生異常聲音。
- 斷路開關、保險絲或漏電斷路器經常短路。
- 運轉開關或按鈕不能正常操作。
- 發出燒焦味。
- 室內機漏水。

關閉電源並聯絡銷售工程師。

停電後

空調機機組會在通電後約3分鐘內重新啟動運轉，請稍微等待。

打雷時

如有雷電打擊的風險，請停止空調機運轉並關閉電源，以保護空調機。



建議定期保養

空調機使用一段時間後會變得骯髒，導致性能下降，建議聯絡銷售工程師，定期清洗和保養空調機。
清潔和保養需要另外收費。

安裝注意事項

	使用本機前請仔細閱讀本說明書中的注意事項。		輕度易燃。
---	-----------------------	---	-------

- 文中描述的注意事項分為「警告」及「注意」兩大類。二者均包含重要安全資訊。請務必遵循所有注意事項。
- 「警告」及「注意」事項的含義。

	警告	若不確實遵循這些指示，可能導致人身傷害甚至死亡。
	注意	若不確實遵循這些指示，可能導致財物損壞或人身傷害，嚴重程度視情況而異。

- 本說明書中的安全標記有以下含義：

	必須遵守。		必須接地。		切勿嘗試。		輕度易燃。
---	-------	---	-------	---	-------	---	-------

- 安裝完成後，請進行運轉測試以檢查有無異常，並向客戶解釋如何參照使用說明書來使用及保養空調機。

警告

重要提示

- 本空調機使用R32冷媒，處理不當可能會造成人命傷亡。在安裝、使用、維修空調機前，請先閱讀本說明書。
- 安裝空調機後必須進行檢漏測試，以確保沒有冷媒洩漏。
- 必須用真空泵排出R32冷媒內的空氣。
- 在安裝、移動、維修空調機時，請勿將指定冷媒（R32）以外的氣體混入製冷系統中。
- 不能將R32冷媒存於有明火的地方，或在該區域點燃火源。
- 安裝空調機時，應採取防靜電措施。
- 如在安裝過程中發現R32冷媒洩漏，必須立即打開所有門窗，保持室內通風。同時，所有人應離開室內，待全部冷媒洩漏後再作處理。如產品已損壞，必須運回維修點維修，禁止於安裝現場進行冷媒喉管焊接等工序。
- 切勿嘗試自行安裝空調機，請委託合資格的技術人員進行安裝。
否則或會導致漏水、觸電或釀成火災。
- 請嚴格遵從本使用安裝說明書的指引安裝空調機，安裝不當會導致漏水、觸電或釀成火災。
- 請使用本空調機的配件以及指定零件。
使用其他零件會導致組件掉落、漏水、觸電或釀成火災。
- 請將本空調機安裝在能夠承重的地方。
如果空調機未有妥善安裝或安裝支架不夠承托力，可能會令機組掉落並釀成意外。
- 進行電氣施工。
電源線容量不足或錯誤連接可能導致觸電或釀成火災。
- 空調機請使用獨立線路，不要與其他機器共用一條線路。
- 空調機應使用獨立線路，請勿使用帶有連接器的電線、延長線或接入其他負載。
如不遵守以上規定，會引致電線發熱、觸電或釀成火災。
- 請使用指定電線連接室內機和室外機。
請固定電線，以免對端子造成不必要的壓力。
連接不當或不穩會令端子過熱或釀成火災。

開箱檢查

- 應在通風良好的地方（打開門窗的房間、開放式露台、通風良好的樓梯間等）打開空調機的箱作檢查，檢查時空間不能存有明火，亦不能該區域點燃火源。
- 打開室外機的箱前應檢查是否有冷媒洩漏在紙箱內；如發現有洩漏情況，不應繼續安裝空調機。

檢查安裝環境

- 安裝空調機前，應檢查室內面積是否符合安裝要求，室內面積不得小於說明書規定的房間最小面積。如未能符合要求，應向用戶說明清楚並拒絕安裝。
- 開始安裝前，應檢查空調機附近的環境，以確保沒有易燃或起火的危險。空調機不得安裝在密封的建築空間內。
- 保持安裝場所通風（打開門窗）。
- 在連接室內機和室外機的電源線和連接線時，請確保電線鋪設妥當，以使電氣部件箱的蓋能夠完全密合。
未能關好電氣部件箱的蓋可能會令端子過熱、引致觸電或釀成火災。
- 回收冷媒時，應在移走冷媒喉管前停止壓縮機運轉。
在冷媒回收期間，如壓縮機仍在運行，而且截止閥打開，拆開冷媒喉管時可能會發生空氣栓塞，對冷媒回路施加壓力並造成破裂，釀成意外。
- 安裝時，必須確保冷媒喉管已連接好，才可啟動機組。
如啟動壓縮機時，未有連接好冷媒喉管，而且截止閥打開，可能會發生空氣栓塞，對冷媒回路施加壓力並造成破裂，釀成意外。
- 必須安裝接地線，接地線不能與煤氣管、水管、避雷針或電話的接地線連在一起。
接地不良會導致觸電或釀成火災，亦可能因雷電等浪湧電流造成機件故障。
- 根據環境要求安裝電源漏電斷路器以避免觸電。
如不安裝電源漏電斷路器，可能導致觸電或釀成火災。
- 安裝高度必須離地板1.8m以上，總製冷劑充填量低於1.84kg的系統不受任何房間面積要求限制。

注意

- 如出現可燃氣體洩漏，請勿安裝空調機
一旦易可燃氣體洩漏而且聚集在空調機附近，會釀成火災。
- 根據本使用安裝說明書安裝排水喉管。
安裝不當會引致漏水。
- 室外機安裝注意事項。
在氣溫長時間低於或接近冰點的寒冷地區，室外機排出的水可能會結冰。如遇到這種情況，建議安裝電子加熱器防止排出的水結冰。
- 按照指示使用力矩扳手來鎖緊擴口螺絲母。
如果鎖得太緊，經過一段時間後會損毀擴口螺絲母，導致冷媒洩漏。
- 安裝室內機時，避免讓面板和前格柵接觸到地面或其他硬物。
連接配管需要將空調機倒放時，需保護面板和前格柵。
防止對面板和前格柵造成刮痕。
- 請勿將室外機安裝在有小動物築巢的地方。
一旦落葉、小動物等進入機器，接觸到內部電氣部件，會導致零件故障或冒煙、起火等狀況。請保持室外機附近環境整潔。
- 移動室外機時，不要擠壓其頂部。
避免鋒利的金屬邊緣造成意外。
- 由於製冷循環會產生高溫，請將連接導線遠離未隔熱的連接配管。
否則會導致電線發熱，觸電或釀成火災。
- 為保護地球環境及保障安全，請不要於大氣排放冷媒。
回收冷媒時必須使用專用的設備。

配件確認

■ 室內機配件

Ⓐ 安裝板	1	Ⓒ 使用安裝說明書	1
Ⓑ 安裝板固定螺絲 M4×25L	7	Ⓓ 遙控器架	1
Ⓒ 無線遙控器	1	Ⓔ 遙控器架固定螺絲 M3×20L	2
Ⓓ AAA乾電池	2	Ⓕ 室內機固定螺絲 M4×12L	2
Ⓕ 隔熱膠布	1		

安裝地點

- 必須經用戶確認安裝位置。

1 室內機

- 室內機安裝位置應：

- 1) 符合安裝圖中的安裝規定。
- 2) 能確保回風及吹風暢通無阻。
- 3) 不會被陽光直射。
- 4) 沒有熱源或蒸汽在附近。
- 5) 不會出現機油蒸發的情況，否則會縮短室內機的使用壽命。
- 6) 確保冷風可以吹到房間任何角落。
- 7) 盡量遠離帶有電子式啟動器燈管（整流型或快速起動型燈管）的地方，否則會縮短遙控器的傳送距離。
- 8) 距離電視、收音機等1m以上，否則會引致畫面變形或產生電磁干擾。
- 9) 盡量避免於房間頂部或室內機下方放置障礙物，以確保舒適氣流運轉的效果。
- 10) 避免前方有金屬物品阻礙，否則會影響無線網絡的訊號。

2 室外機

• 室內機安裝位置應：

- 1) 能夠承受室外機重量及震動，堅固並且不會擴大運轉音量。
- 2) 不會因室外機排出的熱風以及產生的運轉音量為鄰居帶來不便。
- 3) 避開睡房等地方，以免運轉音量影響休息。
- 4) 確保有足夠空間將室外機搬出、搬入。
- 5) 確保有足夠的空氣流通，而且不要在回風口及出風口堆放雜物。
- 6) 沒有易燃氣體洩漏風險。
- 7) 確保室內機、室外機、電源線、連接線都設在離電線、天線、收音機等3m以上，以免空調調機干擾這些電器（由於無線電波的強度不一，即使在3m以外，也有可能聽到噪音）。
- 8) 避免在海邊或其他空氣中鹽、硫化氣體含量較高的地方，否則室外機可能被腐蝕，縮短壽命。
- 9) 避免於室外機下放置易於受潮的物件，以免被室外機排出的水破壞。

注意

不能將室外機懸吊在天花板上，或在室外機上堆積物品。

-⚠ 注意

當空調機安裝在氣溫較低的地方時，請遵守下列事項：

- 1) 為了不讓風吹到，請把室外機的回風口向著室內的牆壁安裝。
- 2) 不要把室外機安裝在強風可吹到室外機回風口的地方。
- 3) 為了避開強風，請在室外機的出風口安裝擋風板。
- 4) 在降雪量大的地方，請將室外機安裝在不會被大雪影響到的地方。

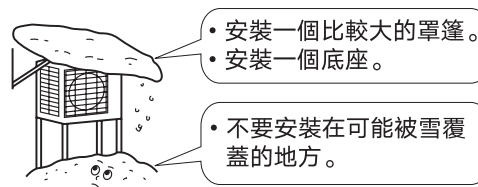

■ 室外機安裝所需空間

- 如室外機的回風口和出風口周圍的牆壁上有障礙物，請按照以下形式安裝。
- 不論使用下列哪一種安裝方式，出風口一側的牆壁不能超過1,200mm。

25/35機型

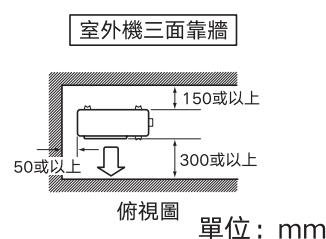
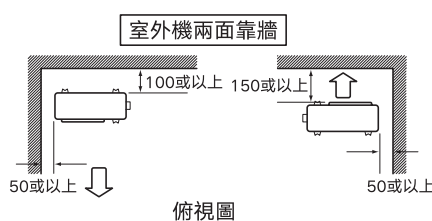
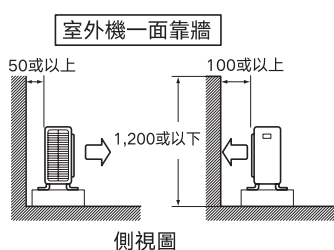

50/60/71機型

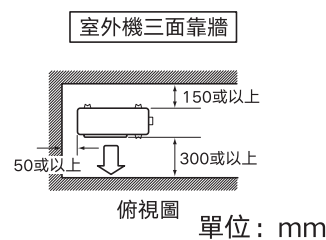
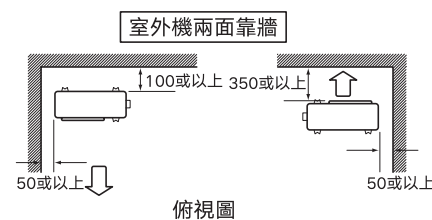
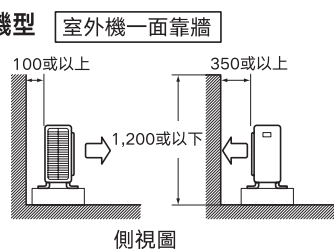

■ 室外機安裝注意事項

- 請確保安裝位置堅固以及處於水平位置，以減少安裝後的運轉震動和音量。
- 參考安裝底座安裝圖，用底座螺絲固定機底（請預備四套M8或M10的底座螺絲、螺母和防震膠，這些零件都可在市面上買到）。
- 將螺絲鎖緊至距離底座表面約20mm的距離。

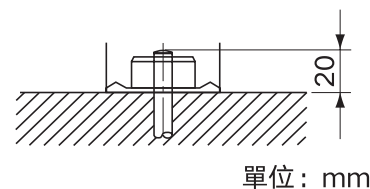

■室內外機安裝圖

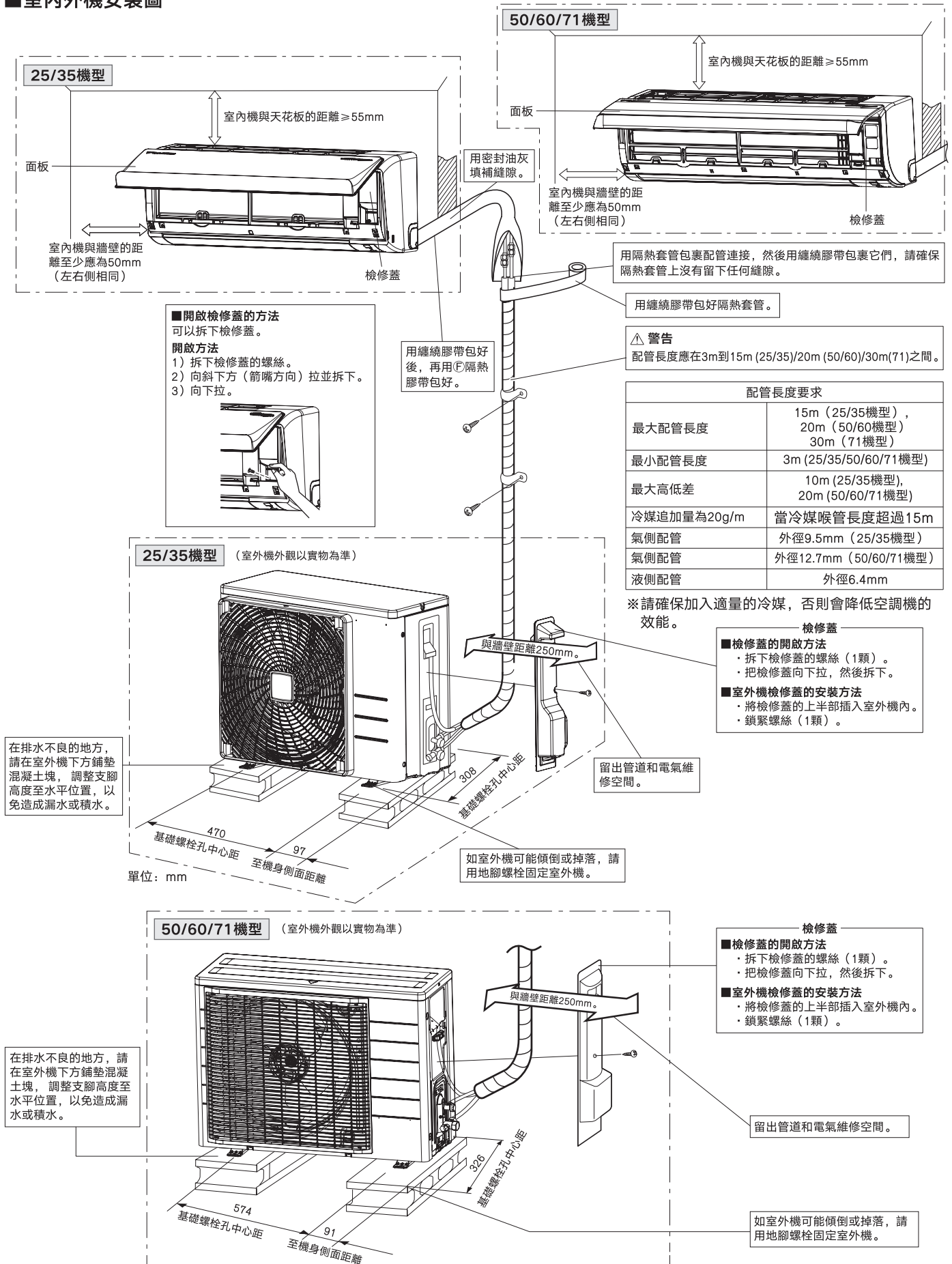

安裝注意事項

1 拆除及安裝前格柵的方法

• 拆除方法

- 1) 拆下面板，然後拆下過濾網。
- 2) 拆下前格柵。
- 3) 前格柵○○○標示處的前方有上部掛鉤（3個位置）。用一隻手將前格柵輕輕拉前，用另一隻手將掛鉤從上向下按。

上部掛鉤 ○○○標示處（3個位置）

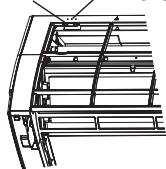

用一隻手將前格柵輕輕拉前，用另一隻手將掛鉤從上向下按（3個位置）

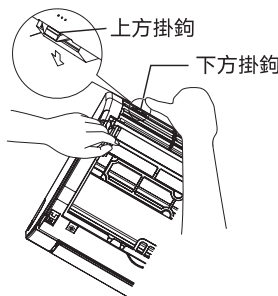

< 與天花板距離太近，沒有操作空間時 >

⚠ 注意

必須穿戴防護手套。

雙手伸入前格柵中間的空隙，一邊向上推，一邊向前拉。

• 安裝方法

- 1) 裝上前格柵，扣好上部掛鉤（3個位置）。
- 2) 鎖緊前格柵的2顆螺絲。
- 3) 安裝過濾網和面板。

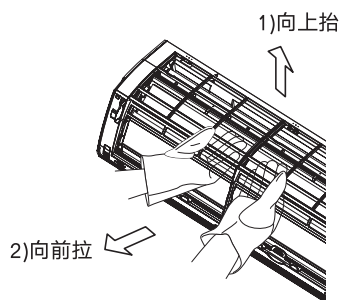

2 如何設定不同地址

如果在同一房間內安裝了2部室內機，請更改其中一部的地址設定。
在斷開電阻時，請注意不要損壞附近的部件。

- 1) 拆下遙控器電池蓋，切斷地址電阻。
- 2) 同時按下TEMP▲、TEMP▼和POWERFUL按鈕。
- 3) 按TEMP▲按鈕，選擇「A」符號，按下POWERFUL按鈕確認。此時，室內機運轉燈會閃爍（約閃爍1分鐘後熄滅）。
- 4) 運轉燈閃爍期間，按下室內機機身的運轉 / 停止按鈕來完成設定。

- 運轉燈熄滅後將無法設定地址，請重新更改設定。
- 完成設定後，長按POWERFUL按鈕約5秒來回復遙控器顯示。

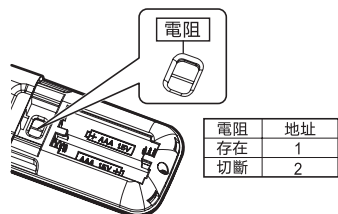

25/35機型

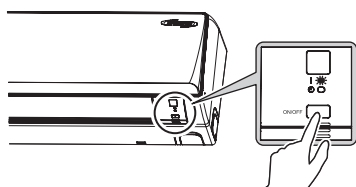

50/60/71機型

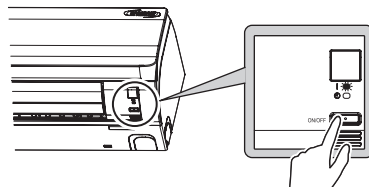

冷媒喉管安裝

1 配管末端喇叭口的加工

- 1) 使用切管器切割配管的末端。
- 2) 為避免金屬雜質或異物進入配管，將切割面朝下，去除毛刺。
- 3) 將擴口螺絲母插入配管。
- 4) 進行配管末端喇叭口加工。
- 5) 檢查配管末端喇叭口加工是否符合標準。
- 6) 完成加工後請保護配管口，以防止碎屑及水份進入。

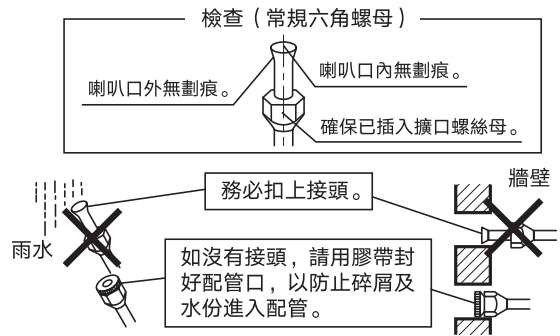
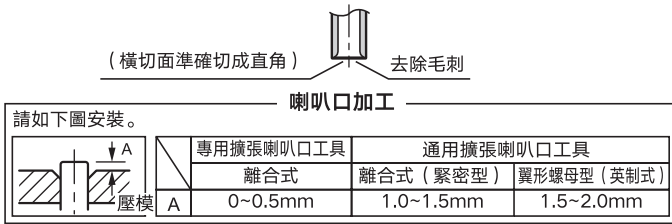

警告

- 1) 不要在喇叭口部份使用礦物油。
- 2) 需防止礦物油進入製冷系統，以免縮短空調機的使用年限。
- 3) 絕對不要重用配管，只可以使用本空調機的配件。
- 4) 不要在空調機上安裝乾燥劑，以免縮短空調機的使用年限。
- 5) 乾燥劑會分解和損壞空調機。
- 6) 請確保配管末端的喇叭口正確加工，不正確的加工會導致冷媒外洩。

2 連接冷媒喉管

- 1) 為防止漏氣，請在喇叭口的內側塗上冷凍機油 (使用適合R32的冷凍機油)。
- 2) 將冷媒喉管連接口對準喇叭口中心，先用手扭3至4下，然後用指定的力矩將它鎖緊。
 - 為防止喇叭口斷開或出現漏氣情況，請用力矩扳手鎖緊。

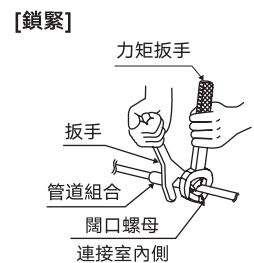
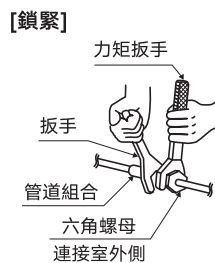
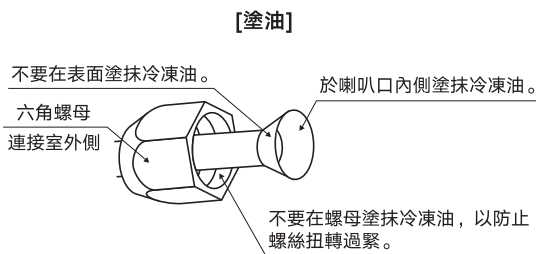

安裝擴口螺絲母的力矩		
氣側		液側
25/35機型	50/60/71機型	
外徑3/8"	外徑1/2"	外徑1/4"
32.7-39.9N·m (333-407kgf·cm)	49.5-60.3N·m (505-615kgf·cm)	14.2-17.2N·m (144-175kgf·cm)

註：必須將冷媒喉管連接口的中心對齊喇叭口、擴口螺絲母的中心，以免導致配管斷開或出現漏氣情況。



2-1. 安裝配管時的注意事項

- 1) 請勿讓雜質或水份混入配管中。
- 2) 當彎曲部份較小，而且曲度不大時，請使用彎管機屈曲。
(彎曲範圍應在30-40mm內。)

2-2. 揀選銅管隔熱

• 選購市面出售的材料時，請遵守以下事項。

1) 隔熱材料：聚乙烯泡沫

導熱熱傳導率：0.041至0.052W/mK
(0.035至0.045kcal/(mh·°C))

(由於氣管的表面溫度最高可達110°C，請盡量使用能承受此溫度以上的材料。)

2) 請使用下列的隔熱材料將氣側配管和液側配管隔熱。

氣側		液側	氣側配管隔熱		液側配管隔熱
25/35機型	50/60/71機型		25/35機型	50/60/71機型	
外徑9.5mm	外徑12.7mm	外徑6.4mm	內徑12~15mm	內徑14~16mm	內徑8~10mm
最小彎曲半徑			厚度10mm或以上		
30mm或以上	40mm或以上	30mm或以上			
管壁厚度：0.7mm (25/35機型), 0.8mm (50/60/71機型)					

3) 氣側配管和液側配管應分開隔熱。

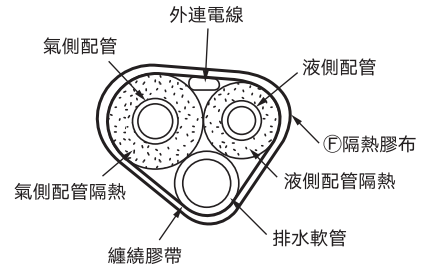

註：如排水軟管包在銅喉上方，可能會影響排水效果或導致積水倒流。

3 工作範圍

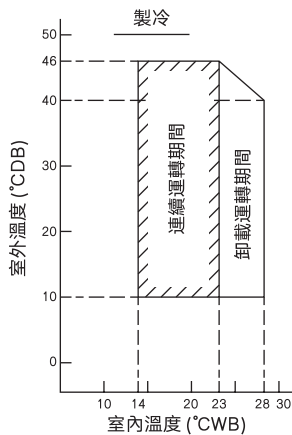

室內機安裝說明

1 安裝板的安裝方法

• 安裝板應安裝在能夠承受室內空調機重量的牆壁上。

- 1) 將安裝板暫時固定到牆壁上，確保板子完全水平，並在牆壁上標記鑽孔點。
- 2) 將安裝板固定在牆上。

建議固定安裝板的位置和尺寸

25/35機型

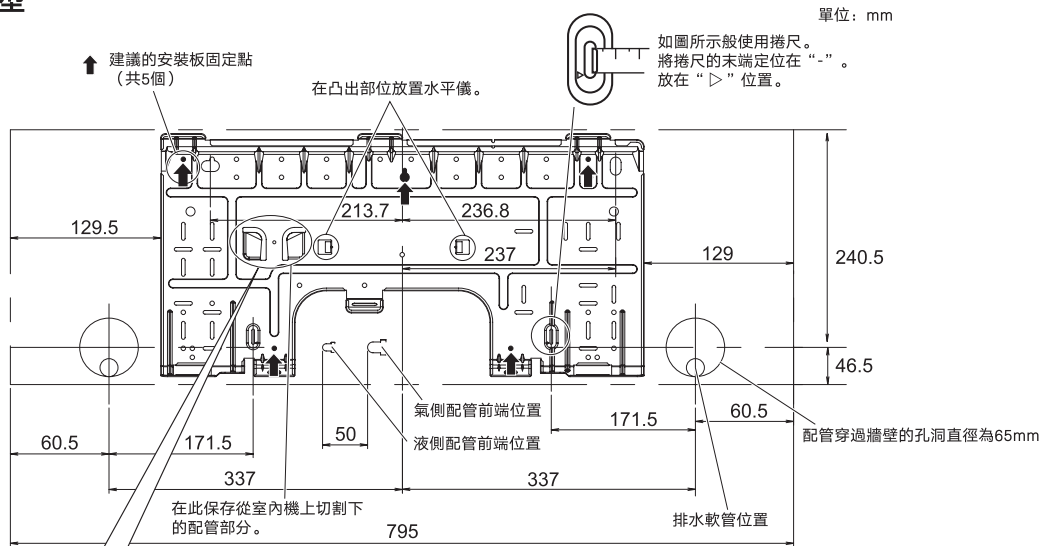

*從室內機上切割下的配管部分應該完整保存在安裝板上，以便在移動機組或其他必要情況下作為備用。

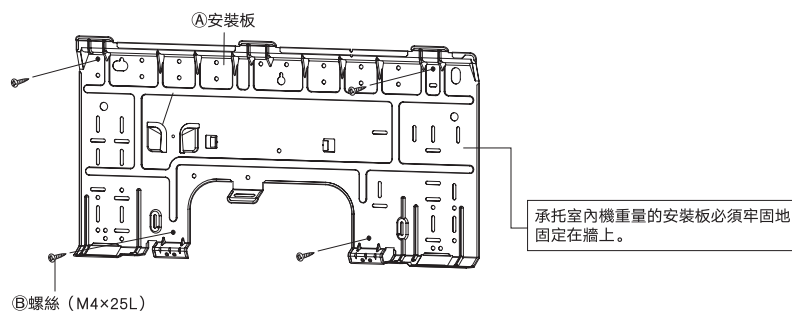
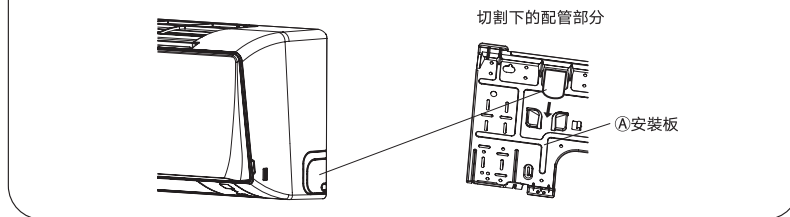

2 牆壁開孔和安裝牆壁孔蓋

- 1) 對於配有金屬框架或金屬板的牆壁，請務必在導通孔中使用牆壁孔蓋，以免發生過熱、觸電或火災。
- 2) 在牆上鑽一個直徑為65mm的導通孔，使其向外傾斜。
- 3) 將牆壁孔蓋插入打通的牆壁孔中。
- 3) 用密封油灰將配管、配線和排水軟管之間的空隙填補起來。

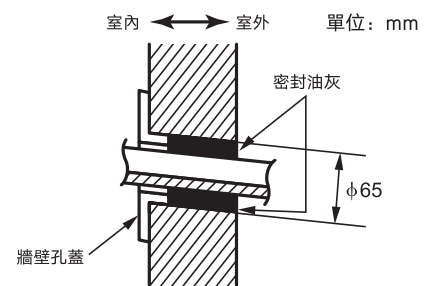

1 安裝板的安裝方法

• 安裝板應安裝在能夠承受室內空調機重量的牆壁上。

- 1) 將安裝板暫時固定到牆壁上，確保板子完全水平，並在牆壁上標記鑽孔點。
- 2) 將安裝板固定在牆上。

建議固定安裝板的位置和尺寸

50/60/71機型

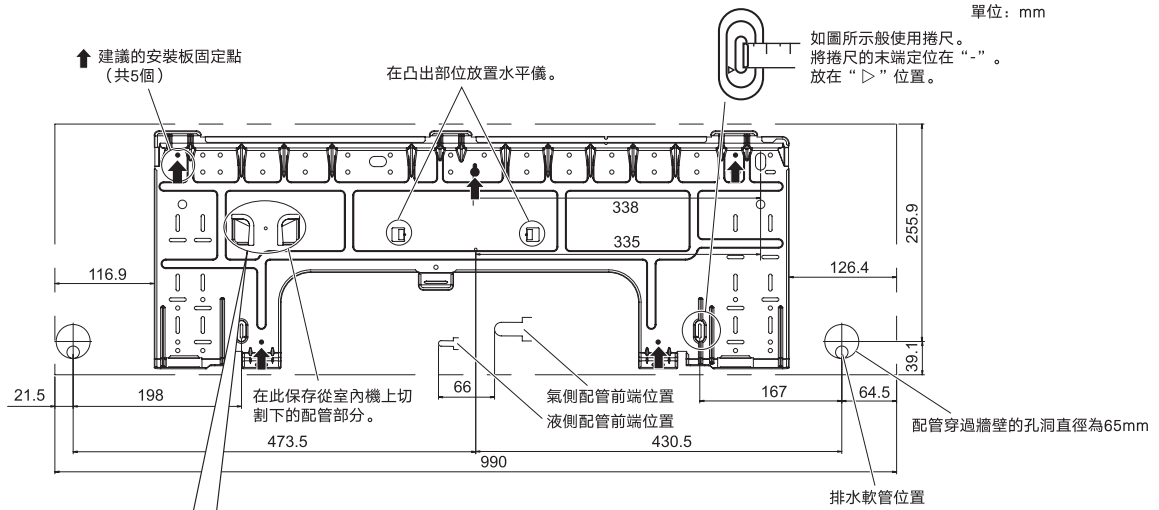

*從室內機上切割下的配管部分應該完整保存在安裝板上，以便在移動機組或其他必要情況下作為備用。

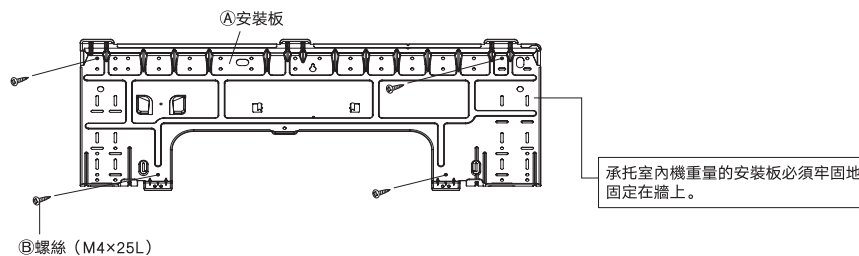
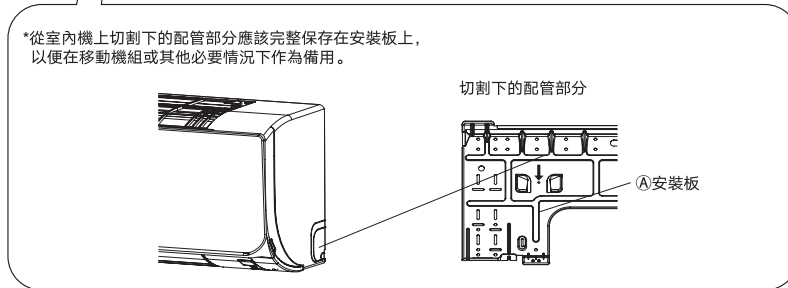

2 牆壁開孔和安裝牆壁孔蓋

- 1) 對於配有金屬框架或金屬板的牆壁，請務必在導通孔中使用牆壁孔蓋，以免發生過熱、觸電或火災。
- 2) 在牆上鑽一個直徑為65mm的導通孔，使其向外傾斜。
- 3) 將牆壁孔蓋插入打通的牆壁孔中。
- 3) 用密封油灰將配管、配線和排水軟管之間的空隙填補起來。

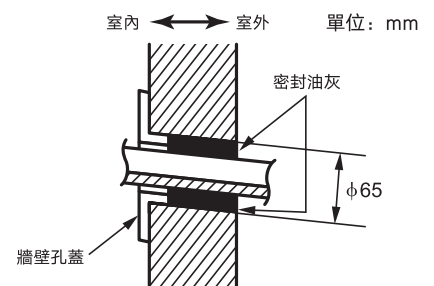

3 室內機安裝

■ 屈曲、整理冷媒喉管時，請注意下列事項：

操作不當會產生異常聲音。

- 1) 不要強行將冷媒喉管壓在底板上。
- 2) 不要強行將冷媒喉管壓向前格柵。

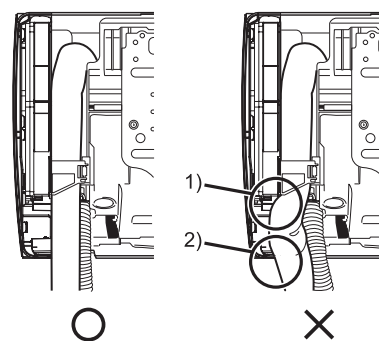

3-1. 右側 / 右後 / 右下配管

- 1) 用膠帶（安裝人員隨身攜帶）將排水軟管固定在配管下側。
- 2) 用隔熱膠帶把冷媒喉管及排水軟管捆綁在一起。
- 3) 將排水軟管和冷媒喉管穿過牆孔，然後根據室內機頂部的△記號，將室內機安裝在安裝板掛鉤上。
- 4) 取下面板，並打開檢修蓋。
- 5) 將室外機的配線從導通孔導入，再從室內機的背面引出，從正面拉出電線。將配線的末端向上屈曲，方便電線導入（如果要先剝離組件間的電線末端，請用粘性膠帶捆綁電線末端）。
- 6) 用雙手按壓室內機的底部框架，將其固定在安裝板掛鉤上。確保電線不會卡在室內機的邊緣上。

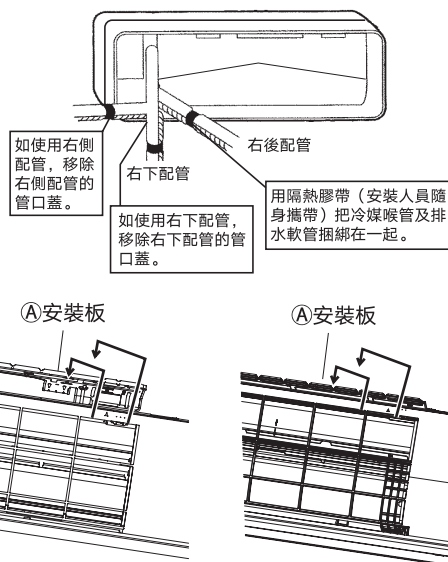

25/35機型

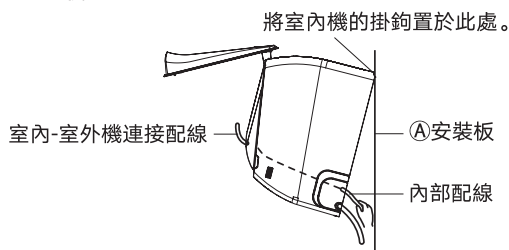

50/60/71機型

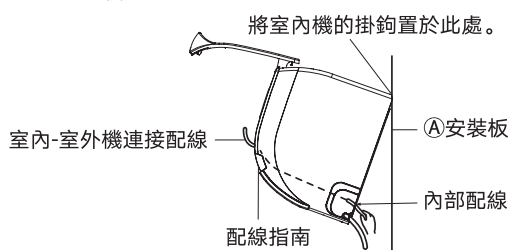

3-2. 左側 / 左後 / 左下配管

更換排水塞和排水軟管位置的方法

• 更換到左側安裝的方法

- 1) 拆下用於固定右側隔熱材料的螺絲，然後拆下排水軟管。
- 2) 按原來樣式重新鎖緊用於固定右側隔熱材料的螺絲。
* 不安裝會導致漏水。
- 3) 拆下左側的排水塞，然後安裝到右側。
- 4) 插入排水軟管，然後用室內機固定螺絲。

排水軟管安裝位置

* 排水軟管在空調機的背面。

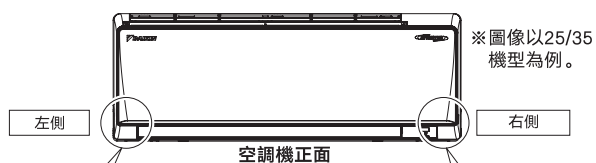

左側安裝時

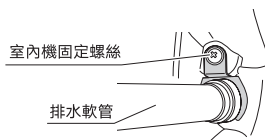

右側安裝時（出廠設定）

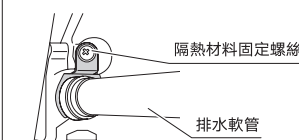

- 1) 用膠帶（安裝人員隨身攜帶）將排水軟管固定在配管的下側。
- 2) 移除排水口的排水塞，插入排水軟管。

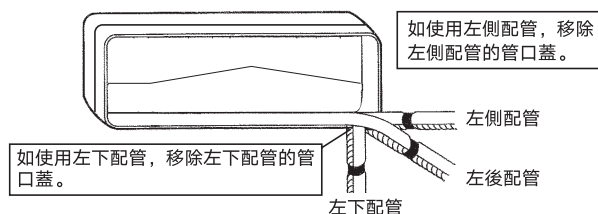

排水塞的安裝方法

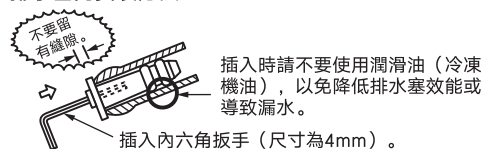

- 3) 將排水軟管和冷媒喉管穿過牆孔，然後根據室內機頂部的△記號，將室內機安裝在安裝板掛鉤上。

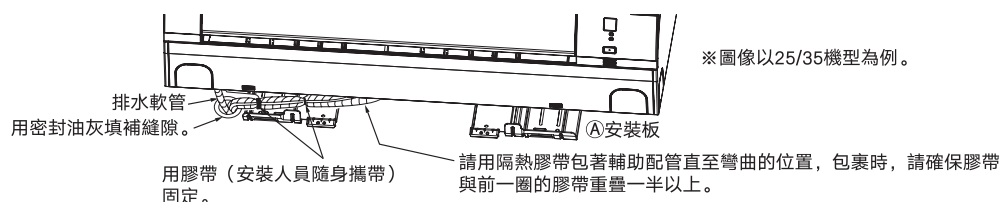

- 4) 引入內部配線。
- 5) 取下底座蓋，切斷管口蓋以連接配管。
- 6) 用膠帶固定冷媒喉管和排水軟管在一起。
- 7) 再用隔熱膠帶把冷媒喉管和排水軟管捆在一起。
- 8) 請確保電線沒有被室內機卡住，同時雙手按住室內機的下方，將室內機掛到A安裝板的掛鉤上。用K室內機固定螺絲（M4×12L）將室內機固定到安裝板上。

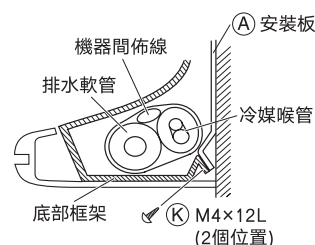

3-3. 導入配管時

請按左側 / 左後 / 左下配管指示安裝。

- 1) 將排水軟管插入至此深度，使其不會從排水喉管中拉出。

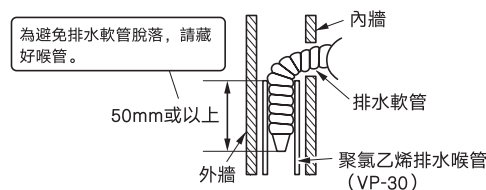

4 配線施工

- 1) 按電線顏色，將電線連接至室內機對應位置，然後用螺絲鎖緊端子。
- 2) 將接地線接入相應端子板。
接地線應在火線、零線、訊號線的下方（如右圖所示）。
連接接地線時請注意不要碰到風扇馬達插接器。
- 3) 輕輕拉一下電線以確認配線已連接，用電線擋塊固定電線。

※圖像以25/35機型為例。

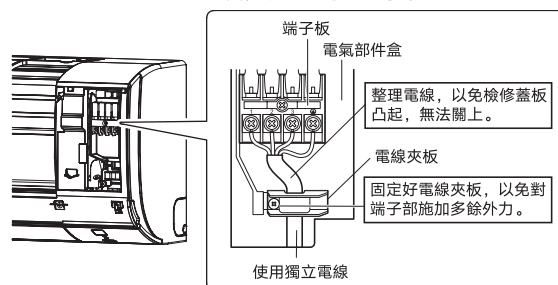

25/35機型

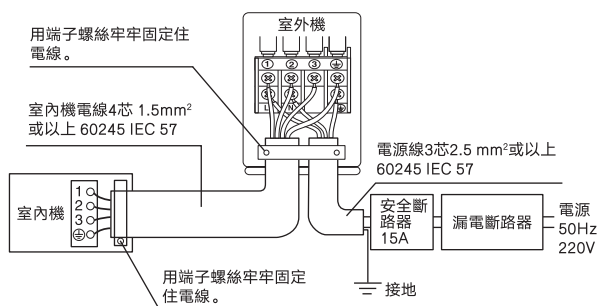

50/60/71機型

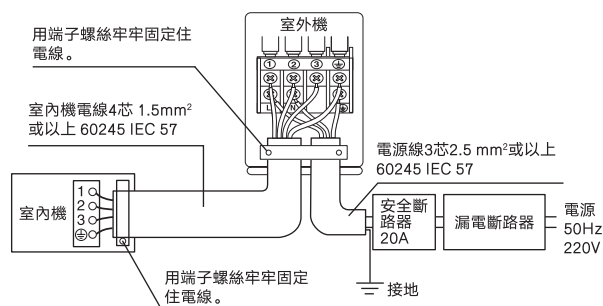

- 4) 為免檢修蓋板凸起，無法關上，請整理好電線才把檢修蓋板蓋上。
- 5) 安裝室內機及室外機之間的連接電線時，應在載流連接前完成接地連接；拆除室內機及室外機之間的連接電線時，應在切斷載流連接後才切斷接地連接。
- 6) 供電前確保所有電線及接地線牢固鎖緊在端子上。

註：室內機電路板上保險絲的規格為：
T3.15A/250VAC (FU1)

⚠ 警告： 保險絲燒掉後，必須請專業技術人員更換，切密自行更換，以免引致觸電或受傷。

⚠ 警告

- 1) 請勿使用帶有連接器的電線、延長線或多組配線，否則可能會導致發熱、觸電或火災。
- 2) 請不要使用非原廠的電子零件（不要從電源端子板上接出排水泵等的電源），以免導致觸電或火災。
- 3) 必須安裝電源漏電斷路器（與高頻諧波型號兼容的）。
（由於本空調機使用變頻器，為防止電源漏電斷路器的誤動作，必須使用與高頻諧波型號兼容的電源漏電斷路器。）

5 排水施工

- 1) 進行排水施工時，需要特別注意下圖所示的情況。
- 2) 檢查排水軟管：拆下過濾網，於排水盤加入適量的水，檢查水流是否順暢。
- 3) 需要延長排水喉管時，可使用市面出售的延長排水軟管，但必須對室內的排水軟管延伸部份進行隔熱。

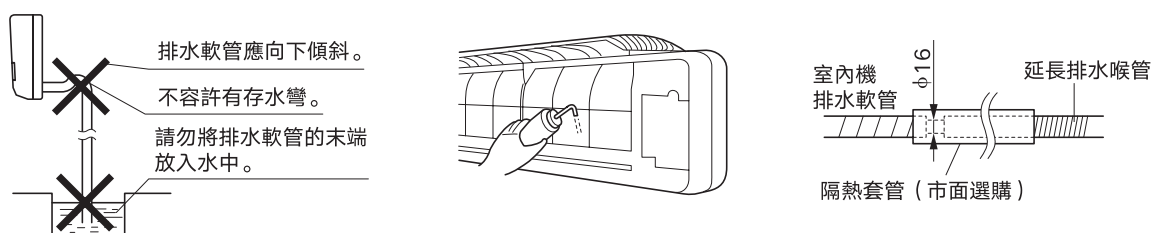

- 4) 在導入配管時，若直接在室內機配備的排水軟管上連接硬質聚氯乙烯喉管（標稱直徑為16mm），請使用市面出售的硬質聚氯乙烯排水喉管接駁口（標稱直徑為16mm）。

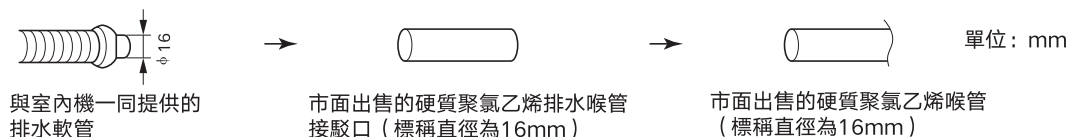

室外機安裝說明

1 安裝室外機

1) 安裝室外機時，請參閱「安裝地點」及「室內外機安裝圖」。

2 配線施工

⚠ 警告

- 1) 請勿使用帶有連接器的電線、延長線、延長電線或支配線連接，否則可能會導致發熱、觸電或火災。
- 2) 請不要使用非原廠的電子零件（不要從端子板分出電源線供排水泵或其他零件使用），以免導致觸電或火災。
- 3) 必須安裝電源漏電斷路器（與高頻諧波型號兼容的）。
（由於本空調機使用變頻器，為防止電源漏電斷路器的誤動作，必須使用與高頻諧波型號兼容的電源漏電斷路器。）
- 4) 安裝室內機及室外機之間的連接電線時，應在載流連接前完成接地連接；拆除室內機及室外機之間的連接電線時，應在切斷載流連接後才切斷接地連接。
- 5) 供電前確保所有電線及接地線牢固鎖緊在端子上。

• 完成所有操作前，請勿打開安全斷路器。
連接電源線端子排時，請遵守下面的注意事項。
連接電線的注意事項。

- 1) 剝開電線的絕緣層（20 mm）。
- 2) 連接室內和室外機之間的機內電線，使端子號碼相匹配。請牢牢擰緊端子螺絲。
我們建議使用平頭螺絲刀擰緊螺絲。
- 3) 先拉一下電線確認沒有斷開，然後用固定件將電線固定在合適的位置上。

※端子台外觀以實物為準。

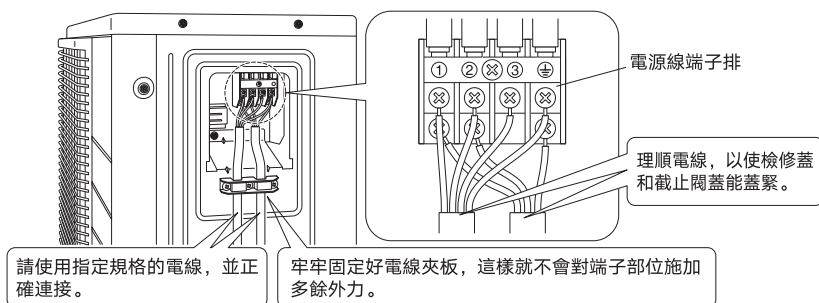

⚠ 警告

請勿使用帶有連接器的電線、延長線或多芯線。
因為使用這些電線可能會導致發熱、觸電或火災。

註：室外機電路板上保險絲的規格為：
T3.15A/250VAC(FU1, FU2)
T20A/250VAC(FU3)(25/35機型)
T30A/250VAC(FU3)(50/60/71機型)

- ⚠ 警告:** 保險絲燒掉後，必須請專業技術人員更換，切密自行更換，以免引致觸電或受傷。連接電源線端子板以及電源線時請注意下列事項。
 (連接扁圓形端子至電源線端子板。請遵守以下預防措施，以避免因不可預見的因素導致端子故障。)

⚠ 注意

- 如果需要使用電線，請務必使用扁圓形端子，以便連接至電源端子排。
將絞線上的扁圓形端子朝上放入覆蓋部位，並固定到定位。
- 當使用單芯電線連接到端子板時，請務必捲曲電線。若處理不當，可能會導致發熱、火災等。

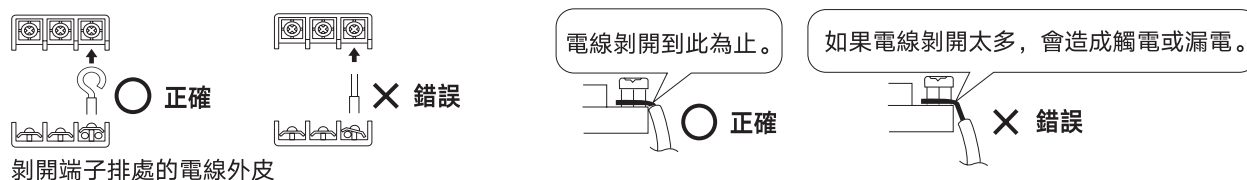

3 排出空氣（抽真空）和漏氣檢查

- 安裝好配管後，應進行通氣檢有沒有漏氣。

⚠ 警告

- 1) 請勿將指定冷媒（R32）以外的氣體混入製冷系統中。
- 2) 如在安裝過程中發現R32冷媒洩漏，必須立即打開所有門窗，保持室內通風。同時，應立即關閉室外機閥門，所有人應離開室內。
- 3) 必須用真空泵排出R32冷媒內的空氣。
- 4) 請使用R32專用真空泵，不同冷媒共用同一個真空泵會損壞真空泵或機組。
- 5) 可通過泡沫檢測法（肥皂水或泡沫）或儀器檢漏法進行漏氣檢查。使用儀器時，不應使用鹵素探頭（或其他使用明火的探測器）。

- 如需要追加冷媒，使用真空泵排出冷媒喉管和室內機內的空氣，然後再追加冷媒。
- 用內六角扳手（尺寸為4mm）操作截止閥桿。
- 所有冷媒喉管的接駁位應使用力矩扳手和指定力矩鎖緊。

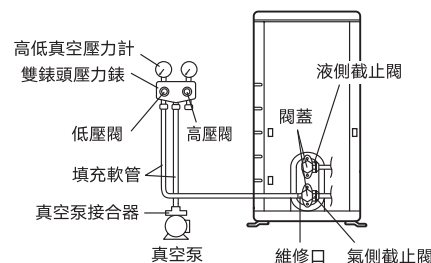

1.將填充軟管（來自雙錶頭壓力錶）的凸出部份連接到氣側截止閥的維修口。

2.完全打開雙錶頭壓力錶上的低壓閥（Lo），完全關閉其高壓閥（Hi）（之後不用再操作高壓閥）。

3.啟動真空泵，檢查高低真空壓力計是否達到-100KPa (-76cmHg)，並確保運轉時間在15分鐘（25/35機型） / 20分鐘（50/60/71機型）以上。

4.關緊雙錶頭壓力錶上的低壓閥（Lo），停止真空泵運轉。
（此狀態應持續3-4分鐘（25/35機型） / 5-6分鐘（50/60/71機型），然後確認高低真空壓力計的指針沒有回復到原位。）

*1

5.扭開液側截止閥和氣側截止閥的閥蓋。

6.用內六角扳手打開液側截止閥桿（向逆時針方向扭轉90°），5秒後關上，檢查氣體洩漏。
請用肥皂水沾在室內機的喇叭口和室外機的喇叭口及閥桿周圍，以檢查有沒有漏氣。檢查完畢後，請仔細擦乾肥皂水。

7.從氣側截止閥的維修口拆下填充軟管，打開液側截止閥和氣側截止閥。
（將閥桿鎖至扭不動的狀態，不要鎖得過緊。）

8.用力矩扳手鎖緊液側截止閥和氣側截止閥的螺母和維修口蓋。

*1 如高低真空壓力計的兩個指針都回到原位，則代表系統摻雜水份或連接部份漏氣。
檢查是否鎖緊所有連接部份以及螺母後，請重複第2至4步。

4 追加冷媒

請參閱室外機銘牌，以確認冷媒種類。（本產品使用R32冷媒。）

追加R32冷媒時的注意事項

- 確保在使用冷媒填充設備時，不會發生不同冷媒間互相污染的情況。填充冷媒的管路應盡量縮短，以減少冷媒在管路內的殘餘量。
- 冷媒瓶要保持垂直向上。
- 確保在填充冷媒前已對製冷系統採取接地措施。
- 不可過量填充冷媒。

安裝R32系統時的特殊注意事項

型號	最低安裝高度要求(m)	R32製冷劑量(kg), 15m管道	R32製冷劑追加量為20g/m(kg), 最大允許管長 (50/60/71機型) ³	最小佔地面積 (基於最大配管長度) ⁴
FTKP25 - RKP25	1.8	0.50	-	不適用
FTKP35 - RKP35	1.8	0.60	-	
FTKP50/60 - RKP50/60	1.8	1.05	1.15	
FTKP71 - RKP71	1.8	1.15	1.45	

1. 根據1.8m的安裝高度計算。
2. 最大配管長度 (L)，單位為m:-15m (25/35機型)/20m (50/60機型)/30m (71機型)。
3. R32製冷劑追加量為20g/m，當冷媒喉管長度超過15m。
4. 總製冷劑量低於1.84kg的系統不受任何房間面積要求限制。
5. 管道工程安裝應保持在最大限制，且管道工程應免於物理損壞且不得安裝在通風不良的空間中。
6. 可重複使用的機械接頭和擴口接頭應可供維護目的之用。
7. 應遵循相關氣體法規。

重要事項

有關所用製冷劑的重要資訊

此產品含有氟化溫室氣體。請勿將氣體排放到大氣中。

製冷劑類型：R32

請用不脫色的墨水筆填寫，

- ① 產品的工廠製冷劑充注量，
- ② 在現場充入的額外製冷劑劑量，以及
- 隨產品提供的製冷劑充注標籤上的總製冷劑充注量。填寫的標籤必須粘附在產品充注口附近（例如，在檢修蓋的內部）。

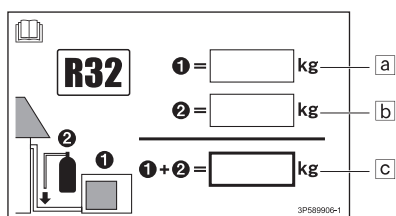

- a 工廠製冷劑充注：請參閱空調機銘牌
- b 充入的額外製冷劑劑量
- c 總製冷劑充注量

5 冷媒回收運轉

為保護地球環境及保障安全，在重組或處理空調機機組的時候，請進行冷媒回收運轉。

- 1) 扭開液側截止閥和氣側截止閥的閥蓋。
- 2) 進行強制冷卻操作。
- 3) 5-10分鐘後，使用內六角扳手關上液側截止閥。
- 4) 2-3分鐘後，關閉氣側截止閥，並停止強制冷卻操作。

如何啟動強制冷卻操作

■ 使用室內機ON/OFF按鈕

按下室內機的ON/OFF按鈕至少5秒（開始運作）。

- 約15分鐘後，強制冷卻操作將自動停止。

按下室內機的ON/OFF按鈕來停止操作。

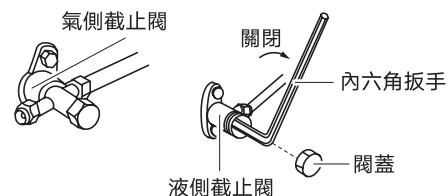

⚠ 注意

- 1) 由於端子板帶有高電壓，按著開關時，不要碰到端子板，否則可能會觸電。
- 2) 關閉液側截止閥後，在3分鐘內關閉氣側截止閥，然後停止強制冷卻操作。

試運轉

1 試運轉

1-1.量度好電源電壓，以確保符合使用要求。

1-2.必須進行製冷運轉的試運轉。

• 測試製冷時，請將空調機設定為最低溫度。

1) 試運轉結束後，請將溫度調回合適的溫度（製冷為26-28°C）。

2) 為保護機組，請不要在停機3分鐘內再度開機。

1-3.按照使用安裝說明書進行測試，以確保所有功能和零件都正常運作。

• 空調機不運轉時也會消耗電力。為免浪費電力，安裝空調機後，如不打算立即使用空調機，請關閉電源。

• 如在空調機運轉期間中斷電源，在接通電源後，空調機會自動回復到斷電前的運轉模式。

2 檢查項目

檢查項目	出現問題時（遙控器顯示故障代碼）	檢查
已正確安裝室內機和室外機。	掉落、震動和噪音	
無冷媒洩漏。	不冷	
安裝的配管帶有適當的隔熱保護（氣側配管、液側配管及室內機排水軟管的延長部份）。	漏水	
已正確安裝排水喉管。	漏水	
系統已正確接地，且接地端已緊固。	漏電時產生危險	
已按說明書指示連接電路。	不能運轉或燒毀	
室內機和室外機的回風口及出風口暢通無阻。截止閥完全打開。	不冷	
無線遙控器訊號傳輸正常。	不能運轉	

維修注意事項

警告

- 如產品需要維修或報銷，必須經由專業、合資格的人士進行。
- 本產品使用R32冷媒，必須按相關規例和本說明書進行維修或報銷程序。

維修人員的資格

- 所有技術人員都應獲取行業認可的評估機構所頒發的有效證書，以確保他們能按照行業標準安全地處理冷媒。
- 只能按照設備製造商制訂的方法維修和保養設備，如需要其他專業人士協助維修和保養設備，應在合資格處理R32冷媒的人士監督下進行。

檢查場地

維修使用R32冷媒的空調前，必須進行安全檢查，將發生火災的風險降到最低。維修製冷系統時，應遵守下列的注意事項。

工作流程

嚴格控制工作流程，以降低由可燃性氣體或蒸汽引起的風險。

一般工作區域

在工作區域內的所有維修人員及其他人士都應該了解目前工作的性質，避免在封閉的空間工作。工作區域應妥善隔離，嚴格管理可燃材料，以確保工作環境的安全。

檢查是否存在冷媒

工作前和工作期間應該使用適當的冷媒監測儀檢查工作區域，確保技術人員知悉該區域可能存在可燃氣體。請確保所用的儀器適用於測量R32冷媒，例如不會產生火花、密封或本質安全的。

放置滅火器

對製冷系統或相關零件進行加熱時，應在附近放置合適的滅火器，例如應在填充冷媒的區域放置乾粉或二氧化碳滅火器。

遠離火源

處理充滿或曾經注入R32冷媒的喉管時，不應使用可能會引起火花或爆炸的任何火源。所有火源（包括香煙）都應該遠離在R32冷媒有機釋放到周邊的環境，包括安裝、維修、移機、棄置的區域。開始工作前，要檢查周圍環境，確保沒有易燃物或起火的危險，亦應在工作區域貼上「禁止吸煙」的標記。

保持通風

打開系統以及進行加熱工序期間，請確保工作區域空氣流通，將洩漏的冷媒稀釋並排放到大氣中。

檢查製冷設備

如要更換電子組件，應按其使用目的和正確的操作規定安裝。必須遵守製造商的保養和維修指南，如有疑問，請向製造商的技術部門查詢。

安裝 R32 空調機時需檢查下列項目：

- 冷媒填充量應取決於房間大小。
- 通風設備運作正常，而且通風口暢通無阻。
- 如果使用間接的製冷循環，應檢查二級迴路中存有冷媒。
- 空調機上的標示清晰，如有模糊的標記或符號，請更換。
- 除非使用耐腐蝕材料或採取腐蝕保護措施，否則不應將冷媒喉管或電子組件安裝在可能與腐蝕性材料接觸的位置。

檢查電氣裝置

維修和保養電子組件應包括初始的安全檢查和各組件的檢查步驟。如發現危及安全的缺陷，應切斷空調機的電源，直至解決缺陷。如無法完全消除危險亦無法停止機組運作，應採取適當的臨時解決方案，同時向用戶報告此情況，以及對所有相關人士作出警告。

初始的安全檢查應包括：

- 電容放電：應以安全的方式完成，以免產生火花。
- 在填充、回收和清洗系統的過程中，沒有暴露在外的電子組件或配線。
- 接地的連續性。

維修密封組件

- 維修密封組件時，在打開密封蓋子時應先切斷設備的供電電源。如在維修過程中必須有電力供應，應不間斷地對最危險的部份進行洩漏檢測，以防止出現潛在的事故。
- 維修電子組件時，應注意不要影響外殼的防護能力。不當的維修方式可能會導致線纜受損、過量連接、端子未按原來的規定安裝、密封受損、密封蓋安裝錯誤等。

確保設備安全地安裝。

確保密封或密封材料不會因老化而失去防止可燃氣體進入的功能，替代配件應符合製造商的要求。

註：使用含矽的密封劑可能會減弱檢漏設備的偵測能力；使用本質安全型組件不必預先隔離。

維修本質安全型組件

若不能確保空調機在使用過程中不超過允許電壓和電流的限制，不能在電路中使用任何永久的電感或電容負載。

本質安全型組件是唯一可以在可燃氣體內繼續運行的組件，測試儀器要設定在正確的檔位上。

如要更換組件，只能使用製造商指定的零件，其他零件可能會導致洩漏在空氣中的冷媒起火。

線路

檢查線路會否被外在因素磨損、腐蝕、過壓、震動，或因鋒利邊緣損毀，同時亦要考慮電線老化，或壓縮機、風扇等的持續震動對電線造成的影響。

檢查R32冷媒

檢查冷媒有沒有在潛在的火源附近洩漏，不應使用鹵素探頭（或其他使用明火的探測器）進行檢測。

洩漏檢測方法

對於R32冷媒系統，可採用以下的洩漏檢測方法：

可用電子檢漏儀可用於檢測R32冷媒，但其靈敏度可能未如理想，或需要重新校準（校準儀器時，應在不含冷媒的環境中進行）。確保檢漏儀不會成為潛在的火源，並且適用於量度的冷媒。

檢漏儀應設定為冷媒的最低可燃濃度（以百分數表示），以所使用的冷媒標定並調節到適當的氣體濃度測試量程（最高25%）。

檢測洩漏所用的液體適用於大部份冷媒，但不要使用含氯的溶劑，以防止氯和冷媒產生反應以及腐蝕銅喉管道。

如懷疑冷媒洩漏，應移走現場所有明火或將火源熄滅。

如果發生洩漏的位置需要進行焊接，應回收所有冷媒，或將所有冷媒隔離在遠離洩漏點的位置（使用截止閥）。進行焊接之前，以及在焊接過程中，要使用無氧氮（OFN）淨化整個系統。

回收和抽真空

維修製冷回路或進行其他工序時，應按常規程序操作，但也應考慮冷媒的可燃性，按以下程序操作：

- 回收冷媒。
- 用惰性氣體淨化管道。
- 抽真空。
- 再次用惰性氣體淨化管道。
- 切割管道或進行焊接。

應把冷媒回收到合適的冷媒瓶中。為確保安全，請用無氧氮吹使系統，此過程可能需要重複數次。此步驟不得使用壓縮氣體或氧氣進行。

吹洗過程是指當系統處於真空狀態時，向系統注入無氧氮達至工作壓力，然後將無氧氮排放到大氣中，最後再將系統抽成真空。重複此過程直至清除系統中的全部冷媒。最後一次注入並排放無氧氮後，可以進行系統焊接。如進行管道焊接，上述操作非常重要。

確保真空泵的出口附近沒有任何點燃的火源，而且通風良好。

填充冷媒程序

除了遵循正常操作程序外，請遵守以下注意事項：

- 確保在使用冷媒填充設備時，不會發生不同冷媒間互相污染的情況。填充冷媒的管路應盡量縮短，以減少冷媒在管路內的殘餘量。
- 冷媒瓶要保持垂直向上。
- 確保在填充冷媒前已對製冷系統採取接地措施。
- 完成填充後（或完成之前），請在系統上貼上標籤。
- 不可過量填充冷媒。

再次進行系統填充前，請用無氧氮進行壓力測試。完成填充後，要在試運行前進行洩漏測試。

在離開該區域前應再進行一次洩漏測試。

棄置

進行此程序前，技術人員應熟悉此設備及其所有特性。建議遵循安全回收冷媒的做法。如需重用回收的冷媒，應首先分析冷媒和油的樣本。測試前應確保已連接到電源。

- 1.熟悉設備和操作。
- 2.切斷電源。
- 3.進行此程序前確保：
 - 如需要使用冷媒瓶回收冷媒，請使用回收機器操作。
 - 個人防護裝備完好且能正常運作。
 - 回收過程要在合資格人士的指導下進行。
 - 回收設備和冷媒瓶應符合相應的標準。
- 4.如果可以，應對製冷系統抽真空。
- 5.如達不到真空狀態，應從多處抽取系統中各個部份的冷媒。
- 6.回收前，應先確保冷媒瓶有足夠的容量。
- 7.按照製造商的操作說明啟動和使用回收設備。
- 8.不要將冷媒瓶裝得過滿（不應注入超過冷媒瓶容量80%的液體）。
- 9.即使是持續短時間，也不得超出冷媒瓶的最大工作壓力。
- 10.在冷媒瓶裝滿及完成工序後，應立即將冷媒瓶和設備移走，並關閉設備上的所有截止閥。
- 11.回收的冷媒在經過淨化和檢驗前，不應注入另一製冷系統。

標示

排空空調機後，應在空調機上標示日期以及空調機所使用的冷媒種類，才可棄置。

回收

維修或棄置空調機時，需清除系統中的冷媒，建議應徹底清除冷媒。

把冷媒裝入冷媒瓶時，只能使用冷媒專用的儲存器。需要確保冷媒瓶的容量與整個系統中的冷媒注入量相符。所有用於回收冷媒的冷媒瓶都應貼好標籤，列明冷媒的種類（即冷媒回收專用瓶）。冷媒瓶應配有完整的卸壓閥和截止閥。如果可以，空的冷媒瓶應在使用前預先抽真空和保持當溫狀態。

回收設備應適用於回收R32冷媒，保持於良好狀態，同時應該操作說明放在方便查閱的地方。

另外，還需要配備計量合格、能夠正常使用的計重秤。

應使用不會洩漏型、可拆接頭連接軟管。

使用回收設備前，應先檢查它們是否處於良好狀態，而且所有電子組件都已密封，以免冷媒洩漏導致火災。

如有疑問，請諮詢製造商。

回收的冷媒應儲存在適當的容器中，附上運輸說明，並退還給冷媒製造商。不要在回收設備（尤其是冷媒瓶）中混合冷媒。

拆除壓縮機或清除壓縮機油時，要確保壓縮機抽真空至合適的水平，以及潤滑油中沒有殘留的R32冷媒。應在把壓縮機退還給供應商前完成抽真空。只能使用電加熱方式加熱壓縮機機殼以加快過程。把油排出系統時，應注意安全。

DAIKIN AIR-CONDITIONING (SUZHOU) CO.,LTD.

Headquarters

Address: No. 578, Zhongxin Avenue East, Suzhou Industrial Park, Suzhou, Jiangsu, China

Postcode: 215126